

ANDROMEDA

Davis Group

2

1

B

B

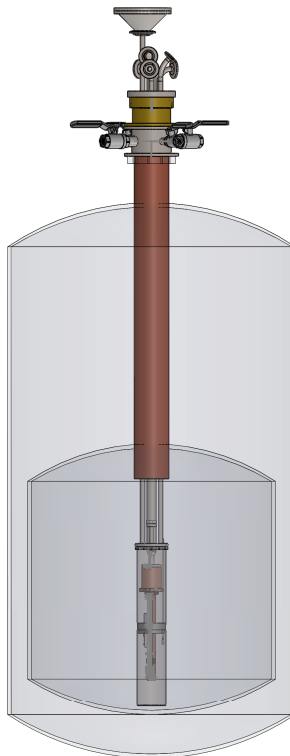

A

A

PROPRIETARY AND CONFIDENTIAL

THE INFORMATION CONTAINED IN THIS DRAWING IS THE SOLE PROPERTY OF SOLIDWORKS. ANY REPRODUCTION IN PART OR AS A WHOLE WITHOUT THE WRITTEN PERMISSION OF SOLIDWORKS IS PROHIBITED.

SOLIDWORKS Student Edition.
For Academic Use Only.

		DIMENSIONS ARE IN INCHES TOLERANCES: FRACTIONAL \pm ANGULAR: MACH \pm BEND \pm TWO PLACE DECIMAL \pm THREE PLACE DECIMAL \pm	NAME	DATE	
			DRAWN		
			CHECKED		
			ENG APPR.		
			MFG APPR.		
			Q.A.		
			COMMENTS:		
		MATERIAL			
		FINISH			
		APPLICATION			
		DO NOT SCALE DRAWING			
		NEXT ASSY			
		USED ON			
			SIZE	DWG. NO.	REV.
			A	assembly full probe	
			SCALE:1:16	WEIGHT:	SHEET 1 OF 1

2

1

SECTION I

Room Temperature Flanges

2

1

B

B

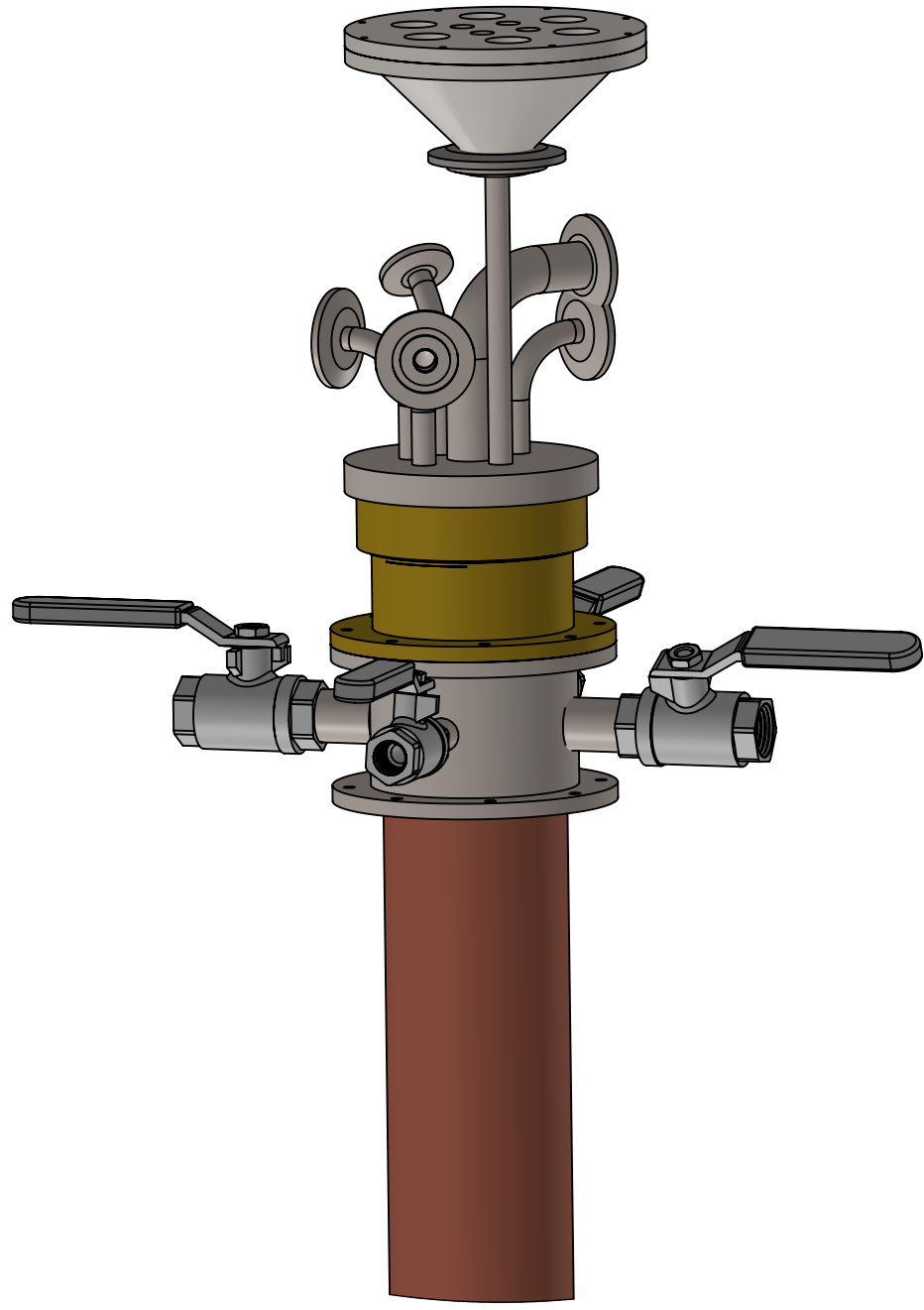

A

A

DETAIL A
SCALE 1 : 3

PROPRIETARY AND CONFIDENTIAL
THE INFORMATION CONTAINED IN THIS DRAWING IS THE SOLE PROPERTY OF SOLIDWORKS. ANY REPRODUCTION IN PART OR AS A WHOLE WITHOUT THE WRITTEN PERMISSION OF SOLIDWORKS IS PROHIBITED.

SOLIDWORKS Student Edition.
For Academic Use Only.

DIMENSIONS ARE IN INCHES TOLERANCES: FRACTIONAL ± ANGULAR: MACH ± BEND ± TWO PLACE DECIMAL ± THREE PLACE DECIMAL ±	MATERIAL	NAME	DATE	SIZE DWG. NO. REV. A assembly full probe top SCALE:1:16 WEIGHT: SHEET 1 OF 1
		DRAWN		
CHECKED				
ENG APPR.				
MFG APPR.				
FINISH	USED ON	COMMENTS:		
APPLICATION	DO NOT SCALE DRAWING			

2

1

2

1

B

B

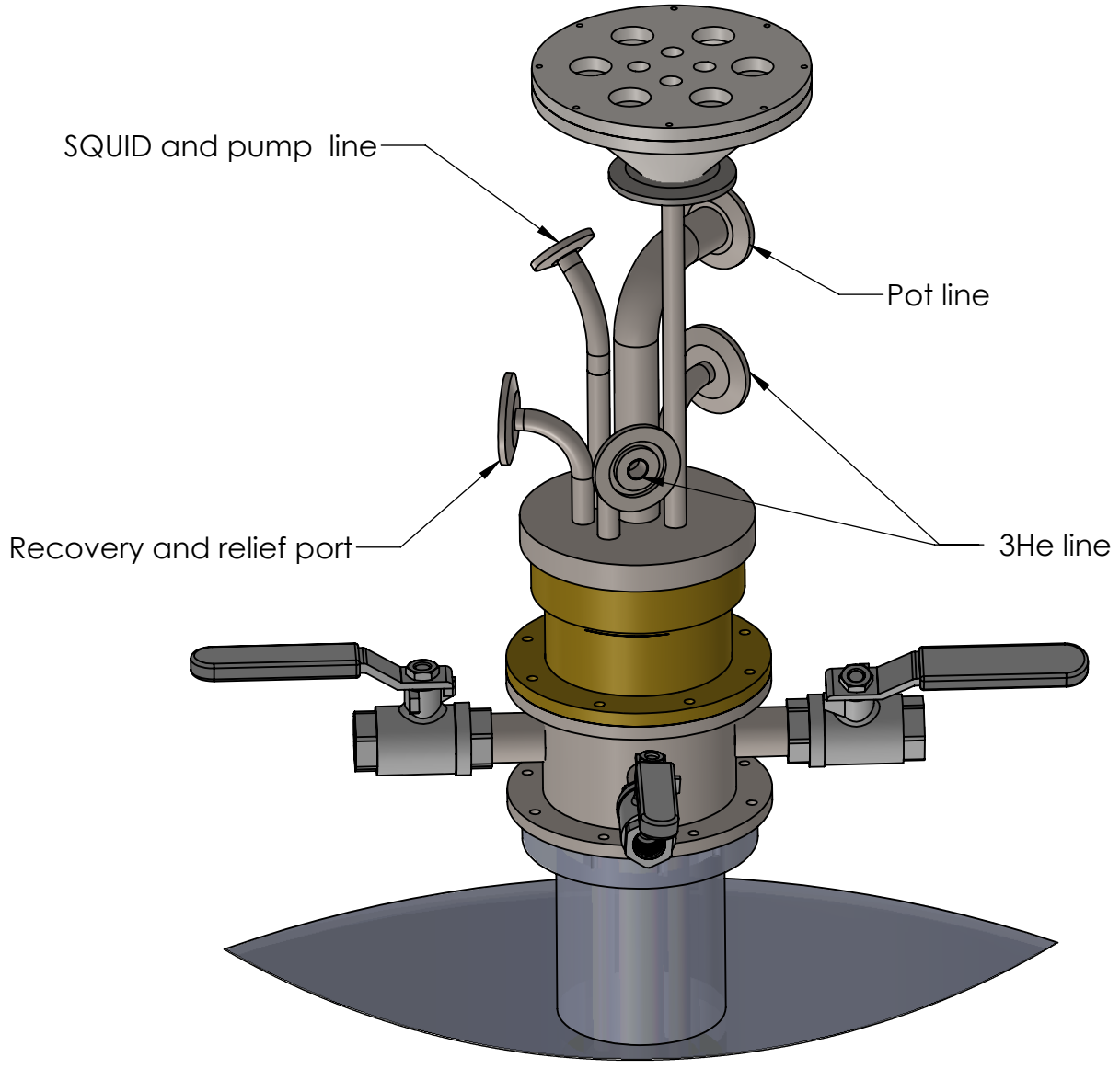

DETAIL C
SCALE 1 : 3

A

A

PROPRIETARY AND CONFIDENTIAL
THE INFORMATION CONTAINED IN THIS DRAWING IS THE SOLE PROPERTY OF SOLIDWORKS. NO REPRODUCTION IN PART OR AS A WHOLE WITHOUT THE WRITTEN PERMISSION OF SOLIDWORKS IS PROHIBITED.

SOLIDWORKS Student Edition.
For Academic Use Only.

		DIMENSIONS ARE IN INCHES TOLERANCES: FRACTIONAL ± ANGULAR: MACH ± BEND ± TWO PLACE DECIMAL ± THREE PLACE DECIMAL ±	NAME	DATE
		MATERIAL	DRAWN	
		FINISH	CHECKED	
		APPLICATION	ENG APPR.	
		DO NOT SCALE DRAWING	MFG APPR.	
			Q.A.	
			COMMENTS:	

SIZE	DWG. NO.	REV.
A	top of probe detail	
SCALE:1:12	WEIGHT:	SHEET 1 OF 1

2

1

2

1

B

B

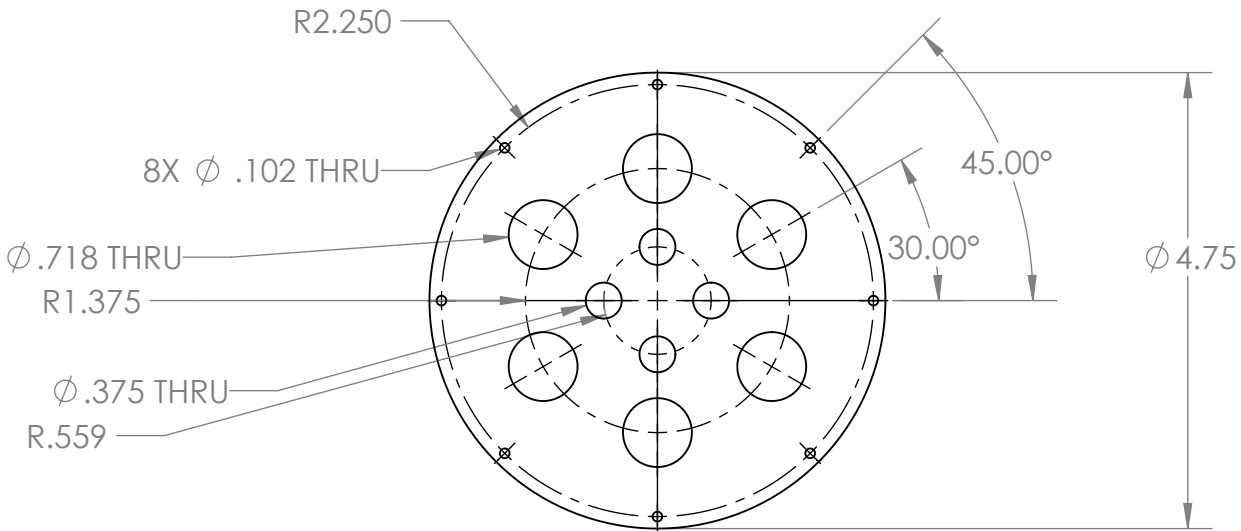
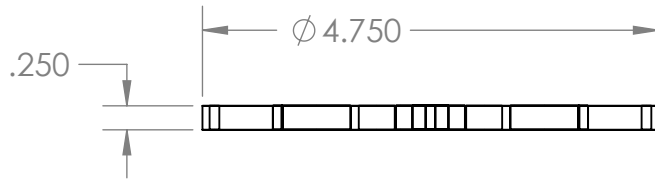
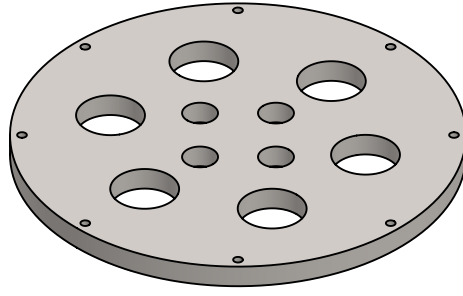

Scale = 1:2

A

A

PROPRIETARY AND CONFIDENTIAL
 THE INFORMATION CONTAINED IN THIS DRAWING IS THE SOLE PROPERTY OF SOLIDWORKS. NO REPRODUCTION IN PART OR AS A WHOLE WITHOUT THE WRITTEN PERMISSION OF SOLIDWORKS IS PROHIBITED.

SOLIDWORKS Student Edition.
For Academic Use Only.

DIMENSIONS ARE IN INCHES	
TOLERANCES:	
FRACTIONAL ±	
ANGULAR: MACH ±	BEND ±
TWO PLACE DECIMAL ±	
THREE PLACE DECIMAL ±	
MATERIAL	
FINISH	
APPLICATION	DO NOT SCALE DRAWING

NAME	DATE
DRAWN	
CHECKED	
ENG APPR.	
MFG APPR.	
Q.A.	
COMMENTS:	

SIZE	DWG. NO.	REV.
SCALE: 1:4	WEIGHT:	SHEET 1 OF 1

Flange for cable connections

2

1

2

1

B

B

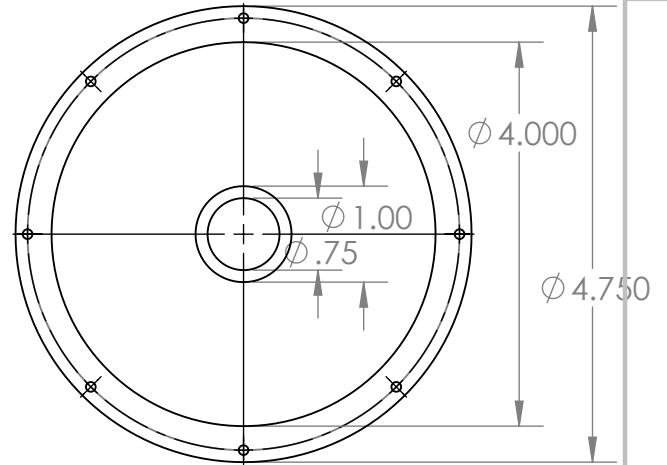
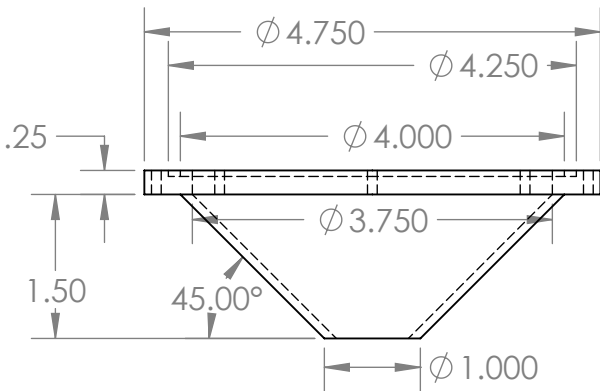
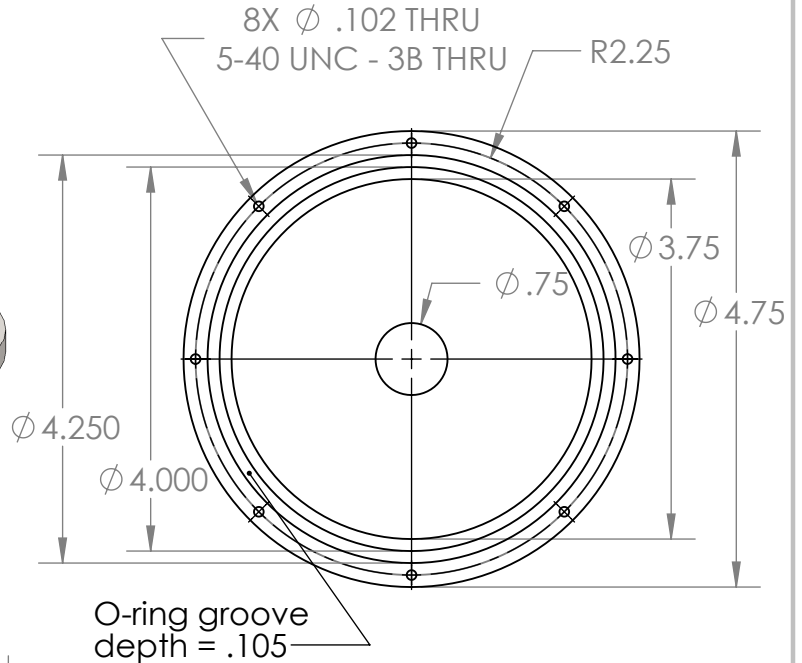
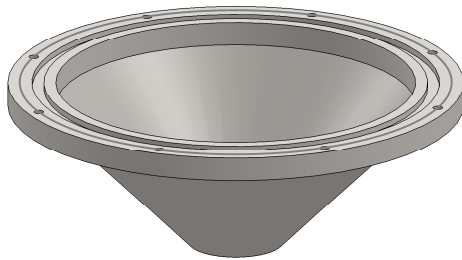

A

A

Scale = 1:2

PROPRIETARY AND CONFIDENTIAL

THE INFORMATION CONTAINED IN THIS DRAWING IS THE SOLE PROPERTY OF SOLIDWORKS. NO REPRODUCTION IN PART OR AS A WHOLE WITHOUT THE WRITTEN PERMISSION OF SOLIDWORKS IS PROHIBITED.

SOLIDWORKS Student Edition.
For Academic Use Only.

		DIMENSIONS ARE IN INCHES TOLERANCES: FRACTIONAL ± ANGULAR: MACH ± BEND ± TWO PLACE DECIMAL ± THREE PLACE DECIMAL ±	NAME	DATE	
			DRAWN		
			CHECKED		
			ENG APPR.		
			MFG APPR.		
			Q.I.A.		
			COMMENTS:		
		MATERIAL			
		FINISH			
		APPLICATION			
		DO NOT SCALE DRAWING			
					SIZE DWG. NO. REV.
					Flange for cable to fridge
			SCALE:1:4	WEIGHT:	SHEET 1 OF 1

2

1

2

1

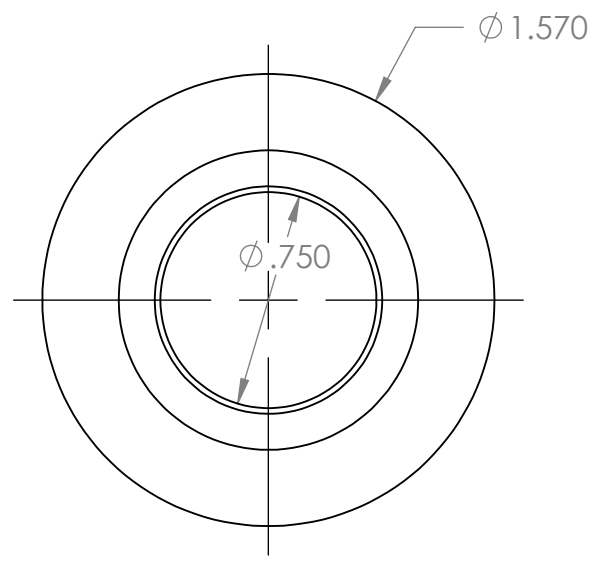
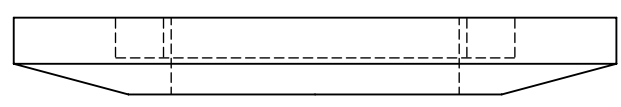
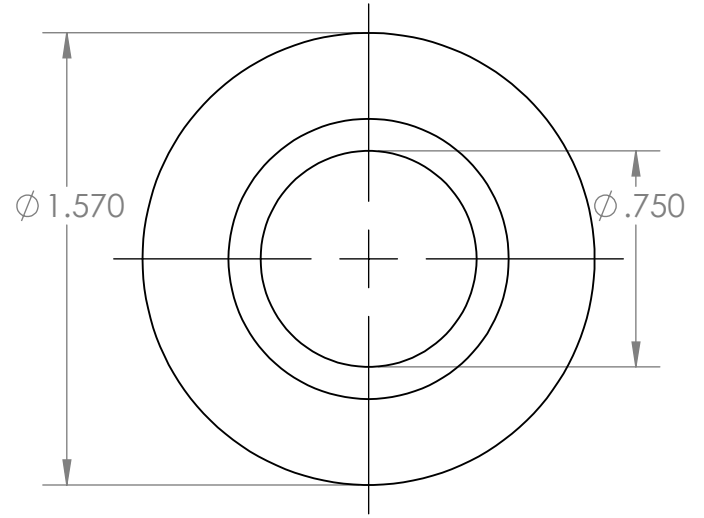
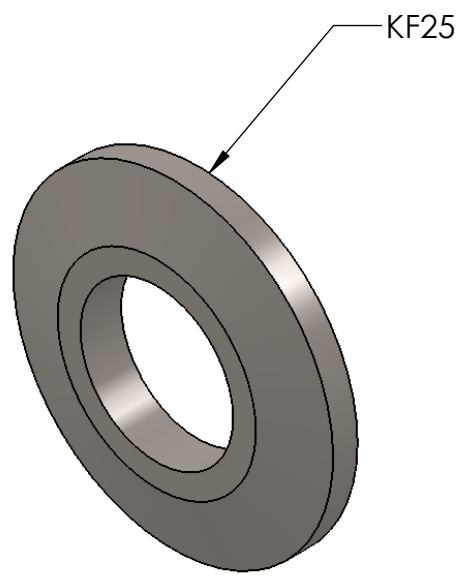

B

B

A

A

Scale= 3:2

PROPRIETARY AND CONFIDENTIAL
 THE INFORMATION CONTAINED IN THIS DRAWING IS THE SOLE PROPERTY OF SOLIDWORKS. NO REPRODUCTION IN PART OR AS A WHOLE WITHOUT THE WRITTEN PERMISSION OF SOLIDWORKS IS PROHIBITED.

SOLIDWORKS Student Edition.
For Academic Use Only.

		DIMENSIONS ARE IN INCHES		NAME	DATE
		TOLERANCES:		DRAWN	
		FRACTIONAL ±		CHECKED	
		ANGULAR: MACH ± BEND ±		ENG APPR.	
		TWO PLACE DECIMAL ±		MFG APPR.	
		THREE PLACE DECIMAL ±		Q.A.	
				COMMENTS:	
		MATERIAL		SIZE DWG. NO.	
		FINISH		A pot flange	
		NEXT ASSY USED ON		REV.	
		APPLICATION		SCALE:2:1 WEIGHT: SHEET 1 OF 1	
		DO NOT SCALE DRAWING			

2

1

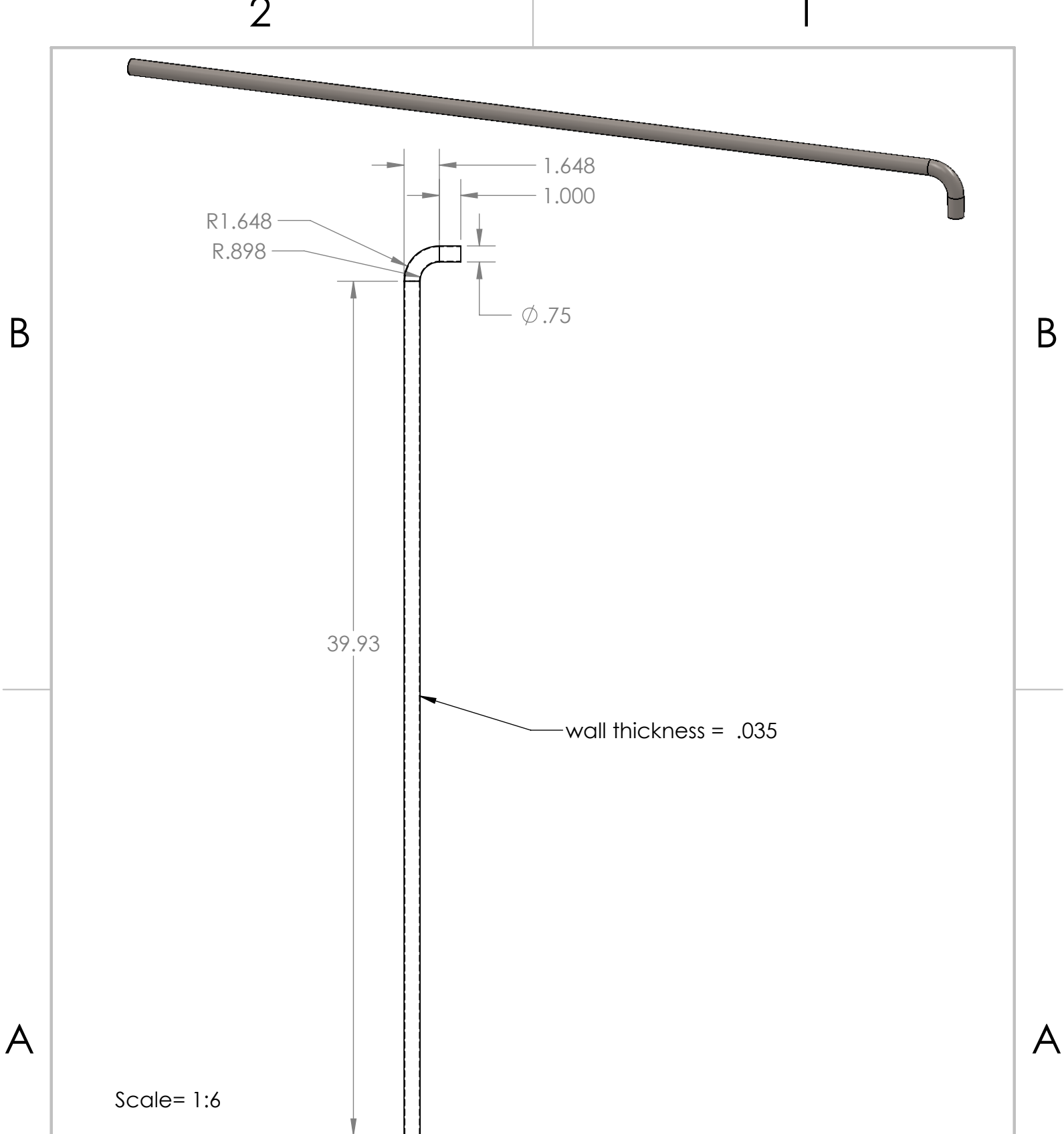

Scale= 1:6

		DIMENSIONS ARE IN INCHES		NAME	DATE
		TOLERANCES:		DRAWN	
		FRACTIONAL ±		CHECKED	
		ANGULAR: MACH ± BEND ±		ENG APPR.	
		TWO PLACE DECIMAL ±		MFG APPR.	
		THREE PLACE DECIMAL ±		Q.A.	
		MATERIAL		COMMENTS:	
<p>PROPRIETARY AND CONFIDENTIAL</p> <p>THE INFORMATION CONTAINED IN THIS DRAWING IS THE SOLE PROPERTY OF SOLIDWORKS. NO REPRODUCTION IN PART OR AS A WHOLE WITHOUT THE WRITTEN PERMISSION OF SOLIDWORKS IS PROHIBITED.</p>		<p>FINISH</p> <p>DO NOT SCALE DRAWING</p>		<p>SIZE DWG. NO. pot line REV.</p> <p>A</p>	
<p>APPLICATION</p>		<p>DO NOT SCALE DRAWING</p>		<p>SCALE:1:8 WEIGHT: SHEET 1 OF 1</p>	

SOLIDWORKS Student Edition.
For Academic Use Only.

2

1

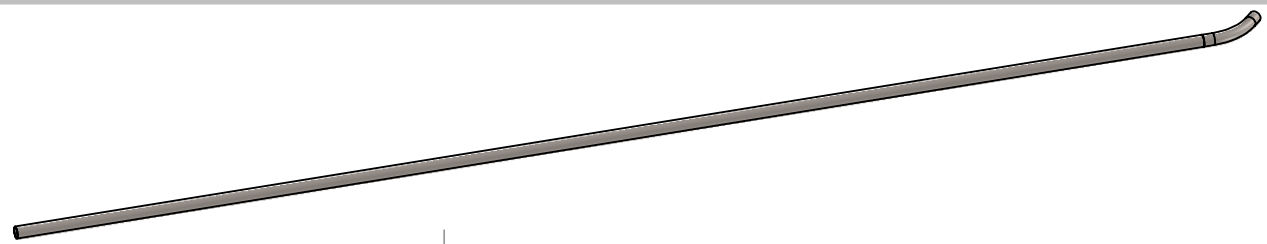

B

B

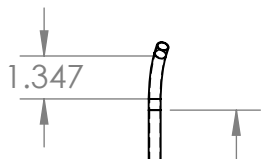

38.928

ϕ .375

wall thickness = .035

A

A

<p>PROPRIETARY AND CONFIDENTIAL</p> <p>THE INFORMATION CONTAINED IN THIS DRAWING IS THE SOLE PROPERTY OF SOLIDWORKS. ANY REPRODUCTION IN PART OR AS A WHOLE WITHOUT THE WRITTEN PERMISSION OF SOLIDWORKS IS PROHIBITED.</p>		DIMENSIONS ARE IN INCHES TOLERANCES: FRACTIONAL \pm ANGULAR: MACH \pm BEND \pm TWO PLACE DECIMAL \pm THREE PLACE DECIMAL \pm	NAME	DATE	<p>Q.A.</p>	REV.	
		MATERIAL	DRAWN				
		FINISH	CHECKED				
		USED ON	ENG APPR.				
		APPLICATION	MFG APPR.				
<p>SOLIDWORKS Student Edition. For Academic Use Only.</p> <p>DO NOT SCALE DRAWING</p>			COMMENTS:		SCALE: 1:8	WEIGHT:	
			SIZE DWG. NO.		SQUID line full		
			SHEET 1 OF 1				

2

1

2

1

B

B

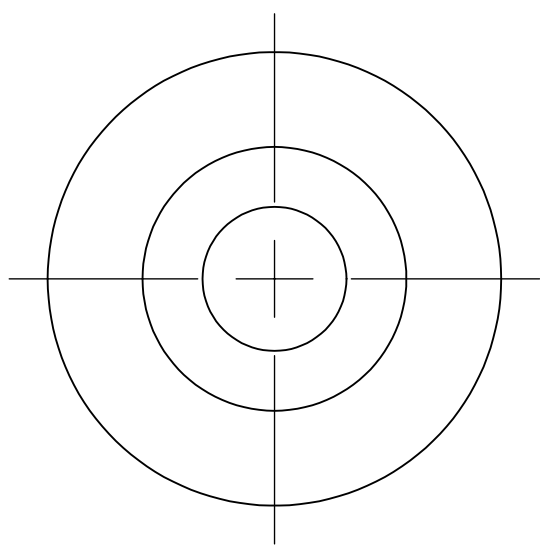
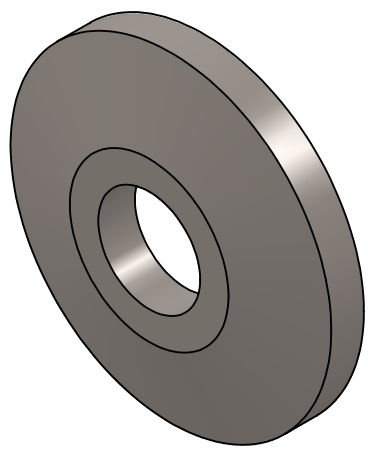

A

A

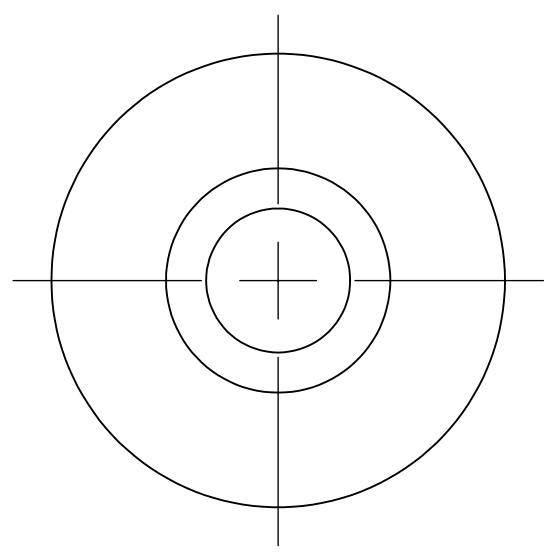
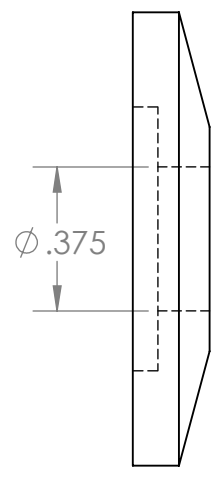

PROPRIETARY AND CONFIDENTIAL
 THE INFORMATION CONTAINED IN THIS DRAWING IS THE SOLE PROPERTY OF SOLIDWORKS. ANY REPRODUCTION IN PART OR AS A WHOLE WITHOUT THE WRITTEN PERMISSION OF SOLIDWORKS IS PROHIBITED.

SOLIDWORKS Student Edition.
For Academic Use Only.

		DIMENSIONS ARE IN INCHES TOLERANCES: FRACTIONAL ± ANGULAR: MACH ± BEND ± TWO PLACE DECIMAL ± THREE PLACE DECIMAL ±			
		MATERIAL			
		FINISH			
		APPLICATION	DO NOT SCALE DRAWING		

	NAME	DATE
DRAWN		
CHECKED		
ENG APPR.		
MFG APPR.		
Q.A.		
COMMENTS:		

SIZE	DWG. NO.	REV.
SCALE:2:1	WEIGHT:	SHEET 1 OF 1

2

1

2

1

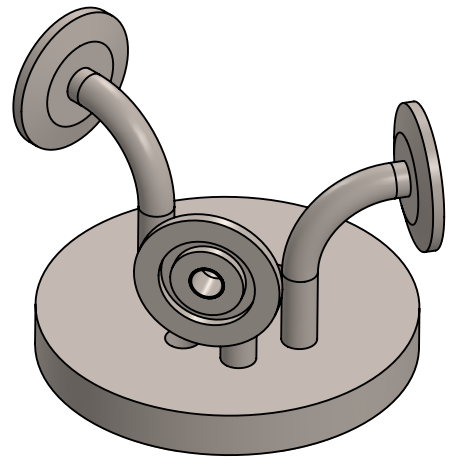

B

B

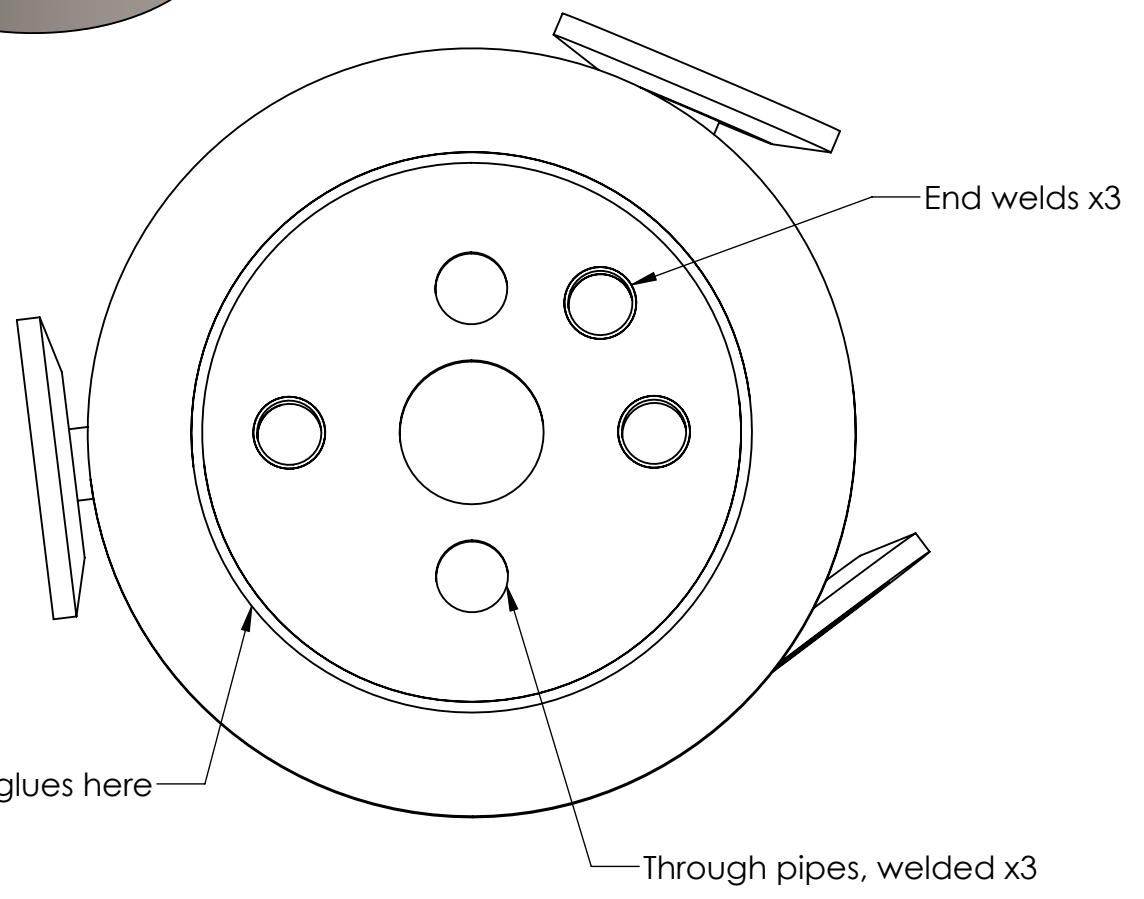

A

A

Scale= 1:1

PROPRIETARY AND CONFIDENTIAL
 THE INFORMATION CONTAINED IN THIS DRAWING IS THE SOLE PROPERTY OF SOLIDWORKS. NO REPRODUCTION IN PART OR AS A WHOLE WITHOUT THE WRITTEN PERMISSION OF SOLIDWORKS IS PROHIBITED.

SOLIDWORKS Student Edition.
For Academic Use Only.

		DIMENSIONS ARE IN INCHES TOLERANCES: FRACTIONAL ± ANGULAR: MACH ± BEND ± TWO PLACE DECIMAL ± THREE PLACE DECIMAL ±	NAME	DATE	
			DRAWN		
			CHECKED		
			ENG APPR.		
			MFG APPR.		
			Q.A.		
			COMMENTS:		
		MATERIAL			
		FINISH			
		APPLICATION			
		DO NOT SCALE DRAWING			
			SIZE	DWG. NO.	REV.
			SCALE:1:2	WEIGHT:	A assembly physical stop
					SHEET 1 OF 1

2

1

2

1

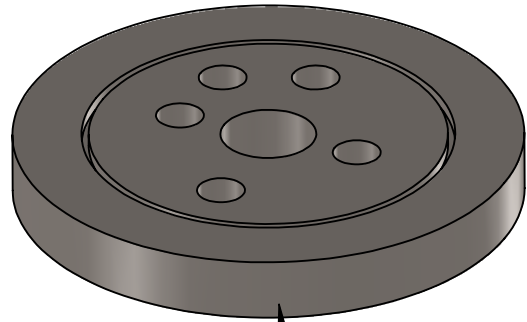
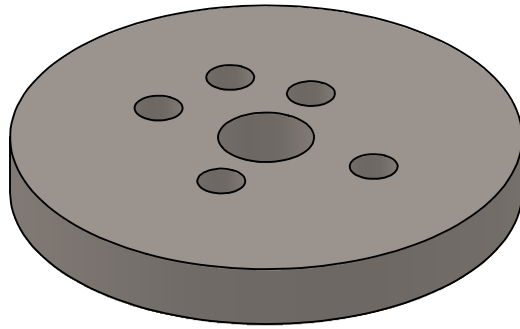

G10 cylinder attaches at the bottom with glue

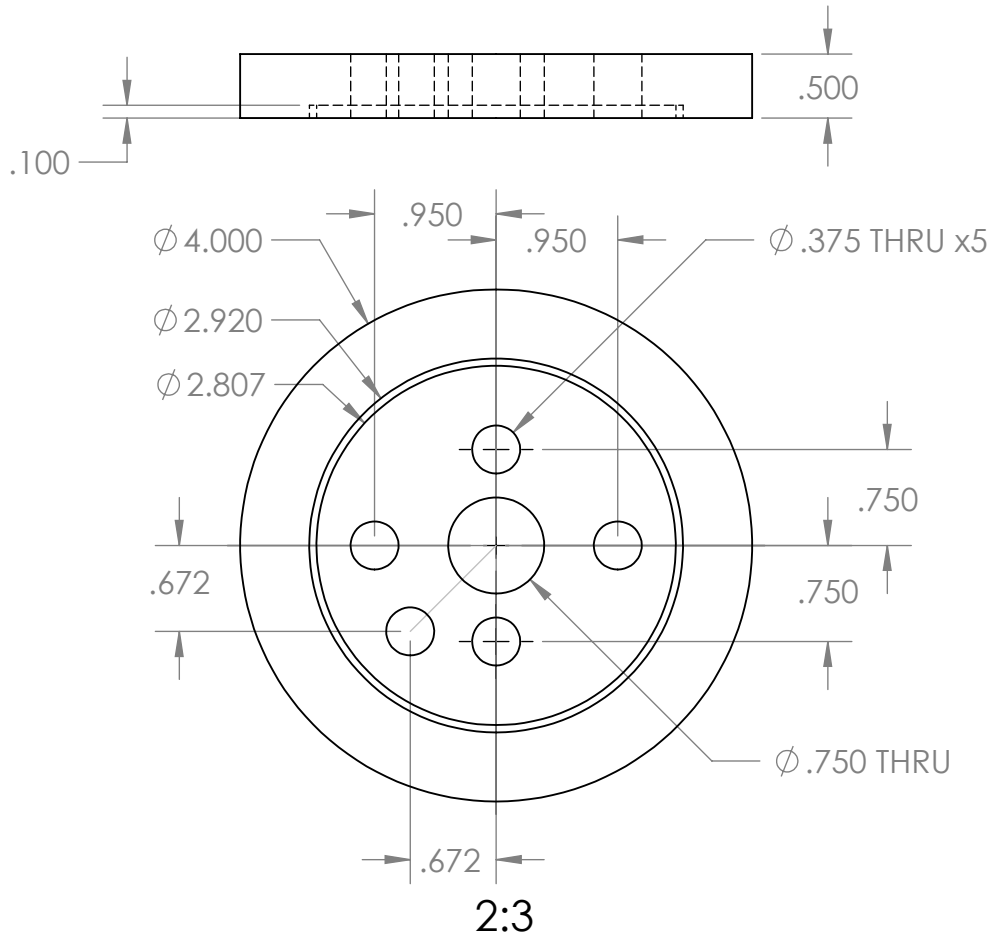

B

B

A

A

PROPRIETARY AND CONFIDENTIAL
 THE INFORMATION CONTAINED IN THIS DRAWING IS THE SOLE PROPERTY OF SOLIDWORKS. ANY REPRODUCTION IN PART OR AS A WHOLE WITHOUT THE WRITTEN PERMISSION OF SOLIDWORKS IS PROHIBITED.

SOLIDWORKS Student Edition.
For Academic Use Only.

DIMENSIONS ARE IN INCHES		NAME	DATE
TOLERANCES:		DRAWN	
FRACTIONAL ±		CHECKED	
ANGULAR: MACH ± BEND ±		ENG APPR.	
TWO PLACE DECIMAL ±		MFG APPR.	
THREE PLACE DECIMAL ±		Q.A.	
MATERIAL SS		COMMENTS:	
FINISH	USED ON	SIZE DWG. NO.	
NEXT ASSY	APPLICATION	A physical stop	
DO NOT SCALE DRAWING		SCALE:1:2	WEIGHT:
		SHEET 1 OF 1	

2

1

SECTION II

Quick Disconnect and Recovery and
Pressure Relief Assembly

2

1

B

B

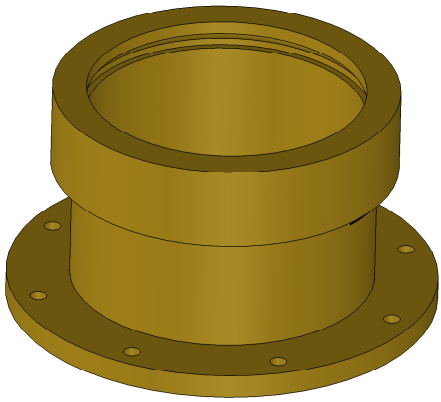

A

A

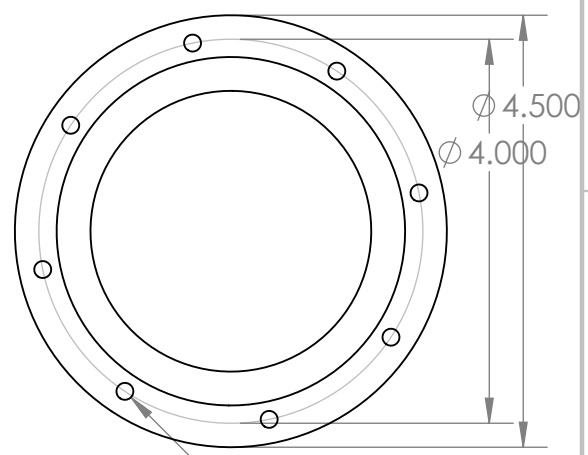
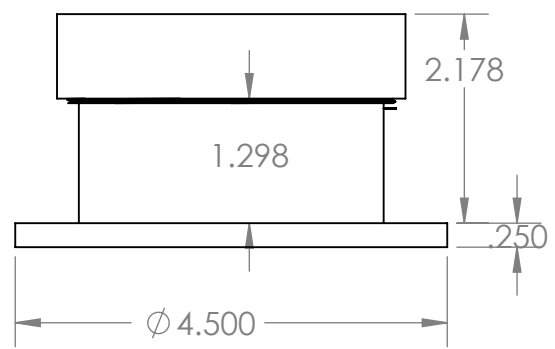

8X Ø .177 THRU ALL

Scale = 1:2

PROPRIETARY AND CONFIDENTIAL
 THE INFORMATION CONTAINED IN THIS DRAWING IS THE SOLE PROPERTY OF SOLIDWORKS. ANY REPRODUCTION IN PART OR AS A WHOLE WITHOUT THE WRITTEN PERMISSION OF SOLIDWORKS IS PROHIBITED.

SOLIDWORKS Student Edition.
For Academic Use Only.

		DIMENSIONS ARE IN INCHES TOLERANCES: FRACTIONAL ± ANGULAR: MACH ± BEND ± TWO PLACE DECIMAL ± THREE PLACE DECIMAL ±	NAME	DATE	
			DRAWN		
			CHECKED		
			ENG APPR.		
			MFG APPR.		
			Q.I.A.		
			COMMENTS:		
		MATERIAL			
		FINISH			
		APPLICATION			
		DO NOT SCALE DRAWING			
					SIZE DWG. NO. REV
					SCALE:1:4 WEIGHT: SHEET 1 OF 1

assembly screw holder for G10 cylinder

2

1

2

1

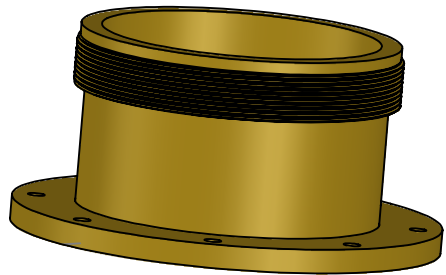

B

B

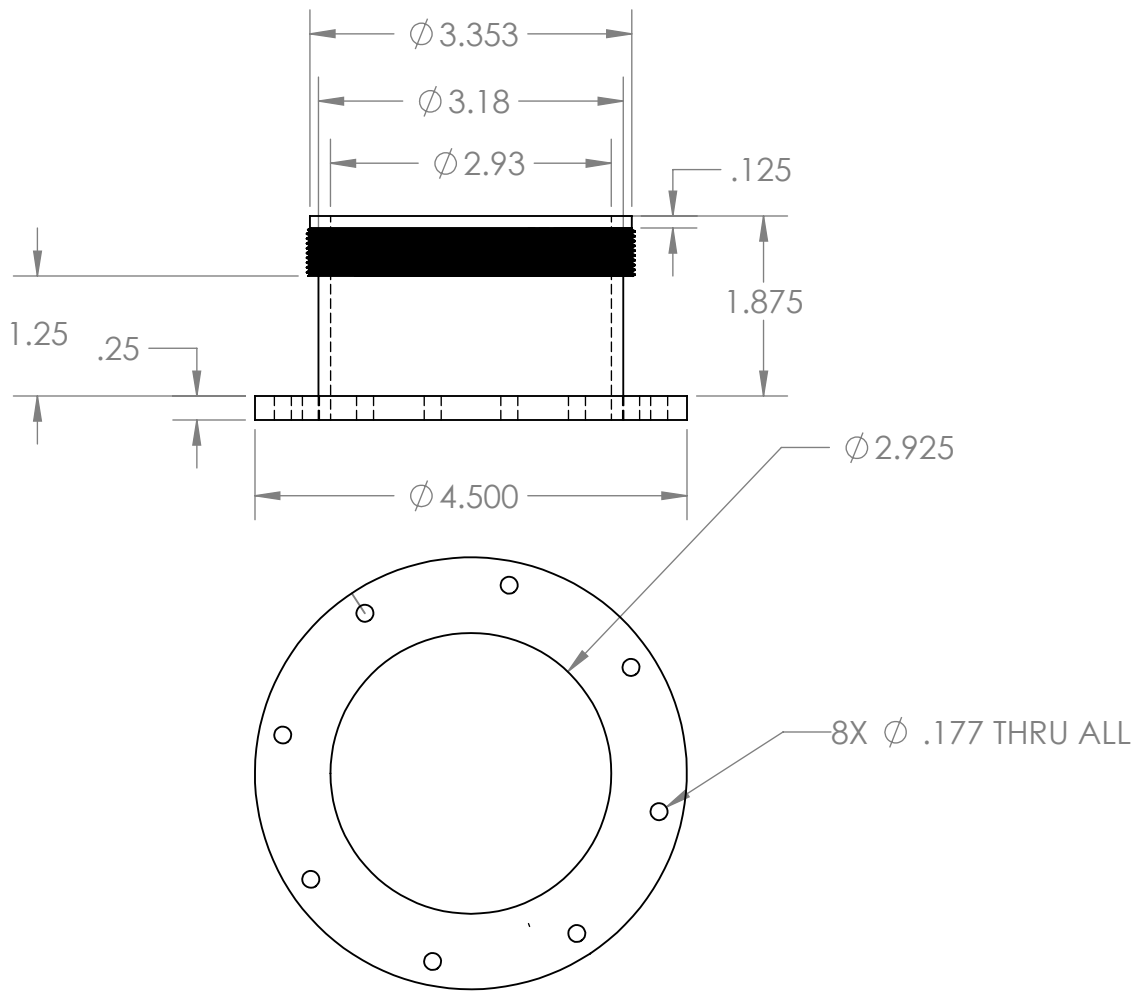

A

A

PROPRIETARY AND CONFIDENTIAL
 THE INFORMATION CONTAINED IN THIS DRAWING IS THE SOLE PROPERTY OF <COMPANY NAME>. ANY REPRODUCTION IN PART OR AS A WHOLE WITHOUT THE WRITTEN PERMISSION OF <COMPANY NAME> IS PROHIBITED.

		DIMENSIONS ARE IN INCHES		NAME	DATE
		TOLERANCES:		DRAWN	
		FRACTIONAL \pm		CHECKED	
		ANGULAR: MACH \pm BEND \pm		ENG APPR.	
		TWO PLACE DECIMAL \pm		MFG APPR.	
		THREE PLACE DECIMAL \pm		Q.A.	
		MATERIAL		COMMENTS:	
NEXT ASSY	USED ON	FINISH			
APPLICATION		DO NOT SCALE DRAWING			
				SIZE	DWG. NO.
				SCALE:1:2	WEIGHT:
				REV.	
				SHEET 1 OF 1	

screw holder for G10 cylinder one piece

2

1

2

1

B

B

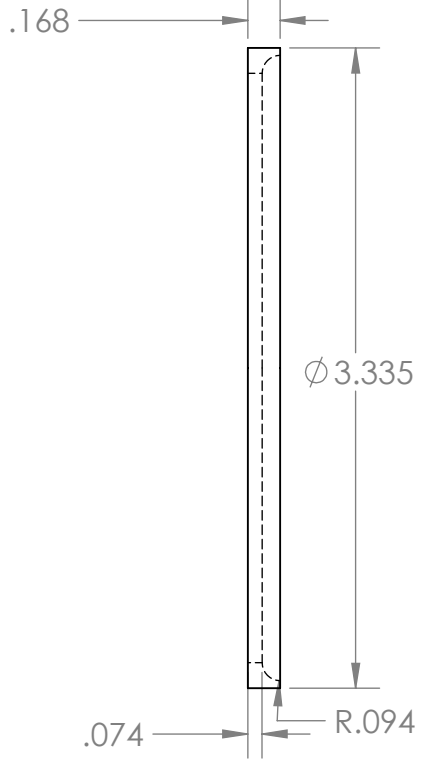
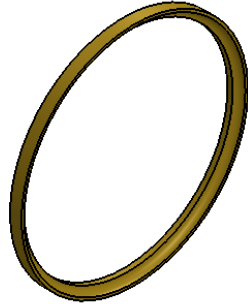

A

A

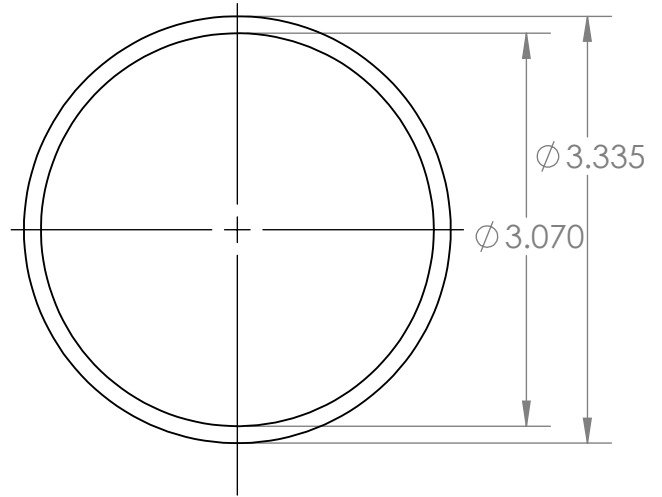
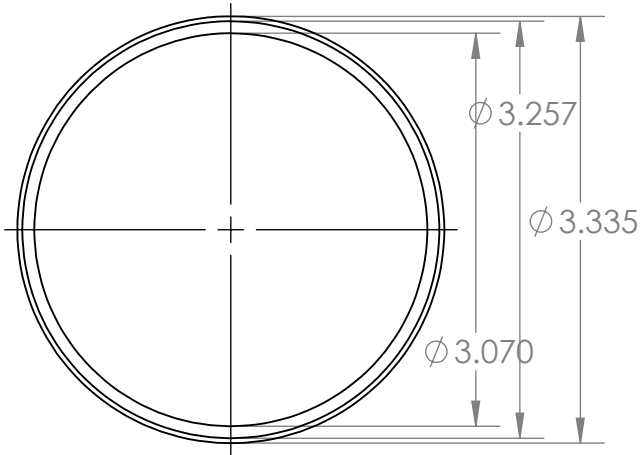

PROPRIETARY AND CONFIDENTIAL
 THE INFORMATION CONTAINED IN THIS DRAWING IS THE SOLE PROPERTY OF SOLIDWORKS. NO REPRODUCTION IN PART OR AS A WHOLE WITHOUT THE WRITTEN PERMISSION OF SOLIDWORKS IS PROHIBITED.

SOLIDWORKS Student Edition.
For Academic Use Only.

		DIMENSIONS ARE IN INCHES TOLERANCES: FRACTIONAL ± ANGULAR: MACH ± BEND ± TWO PLACE DECIMAL ± THREE PLACE DECIMAL ±			
		MATERIAL			
		FINISH			
		APPLICATION	DO NOT SCALE DRAWING		

	NAME	DATE
DRAWN		
CHECKED		
ENG APPR.		
MFG APPR.		
Q.A.		
COMMENTS:		

SIZE	DWG. NO.	REV.
SCALE:1:2	WEIGHT:	SHEET 1 OF 1

screw holder for G10 cylinder o-ring holder

2

1

2

1

B

B

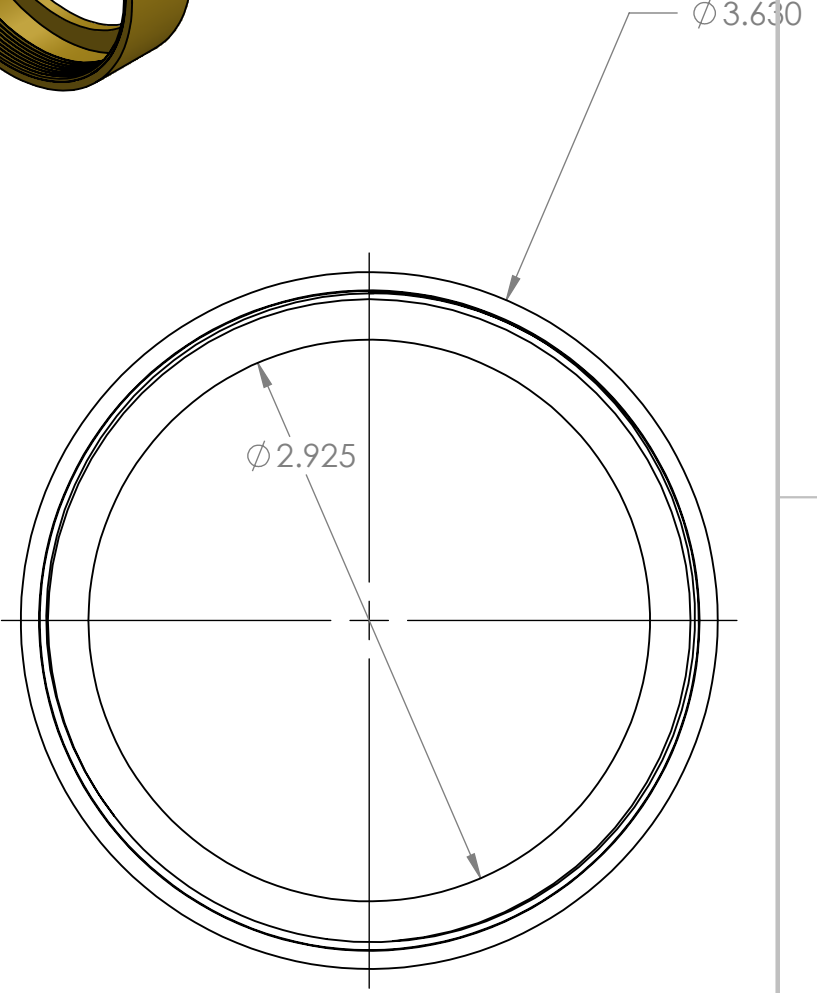
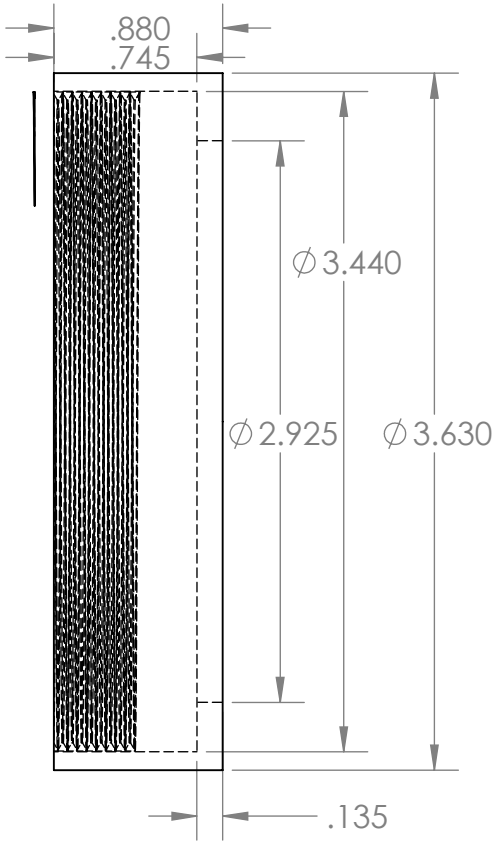

Scale= 1:2

A

A

PROPRIETARY AND CONFIDENTIAL
 THE INFORMATION CONTAINED IN THIS DRAWING IS THE SOLE PROPERTY OF SOLIDWORKS. NO REPRODUCTION IN PART OR AS A WHOLE WITHOUT THE WRITTEN PERMISSION OF SOLIDWORKS IS PROHIBITED.

SOLIDWORKS Student Edition.
For Academic Use Only.

		DIMENSIONS ARE IN INCHES TOLERANCES: FRACTIONAL \pm ANGULAR: MACH \pm BEND \pm TWO PLACE DECIMAL \pm THREE PLACE DECIMAL \pm			
		MATERIAL			
		FINISH			
		APPLICATION	DO NOT SCALE DRAWING		

	NAME	DATE
DRAWN		
CHECKED		
ENG APPR.		
MFG APPR.		
Q.A.		
COMMENTS:		

screw header for G10 cylinder with int thread

SIZE	DWG. NO.	REV.
SCALE:1:1	WEIGHT:	SHEET 1 OF 1

2

1

2

1

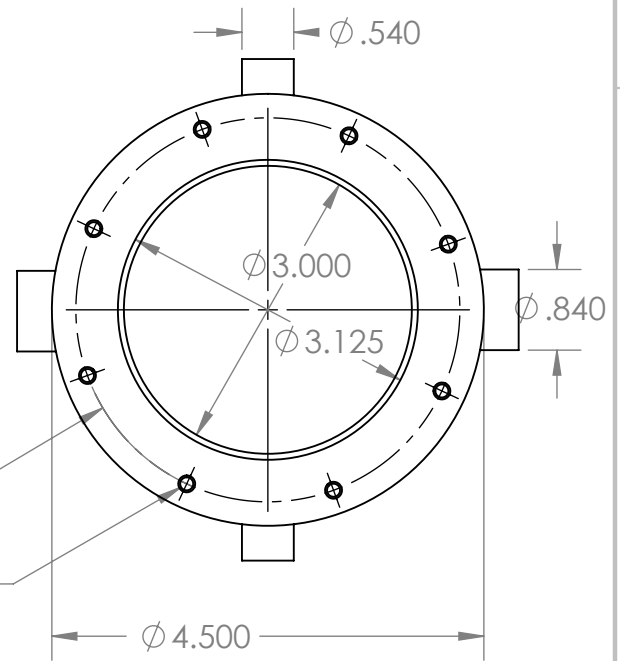
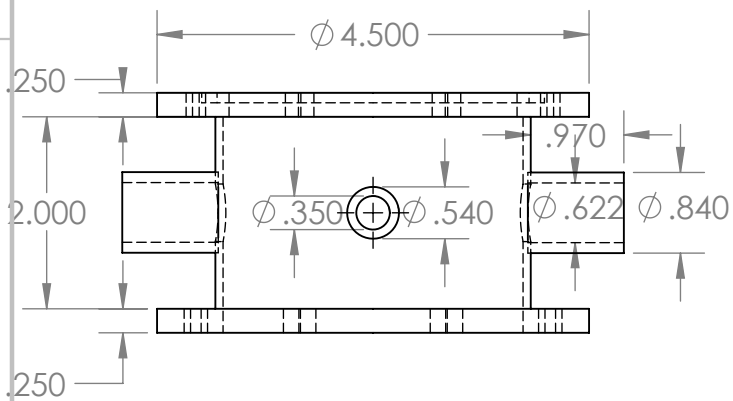
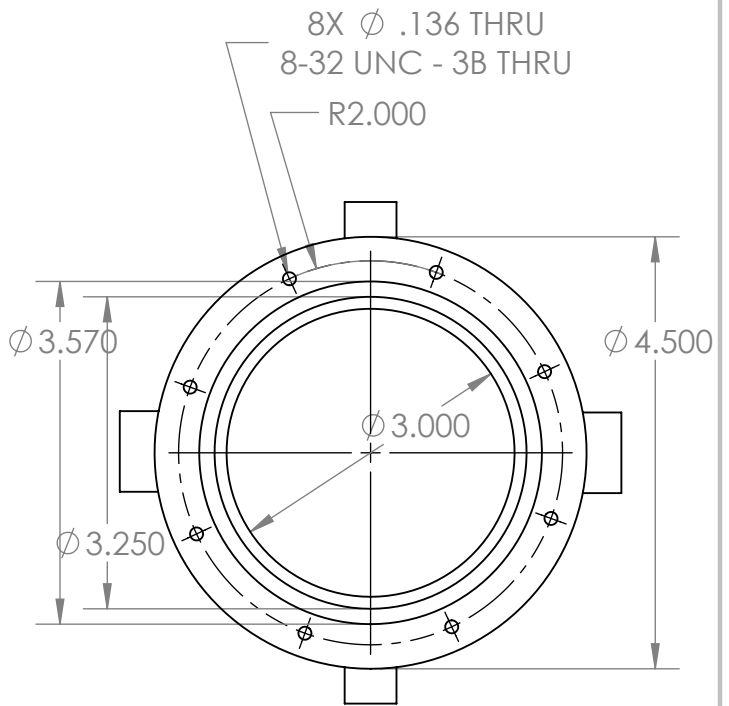
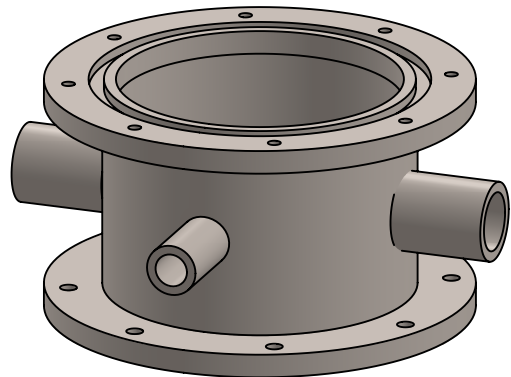

Scale = 1:2

B

B

A

A

PROPRIETARY AND CONFIDENTIAL
 THE INFORMATION CONTAINED IN THIS DRAWING IS THE SOLE PROPERTY OF SOLIDWORKS. NO REPRODUCTION IN PART OR AS A WHOLE WITHOUT THE WRITTEN PERMISSION OF SOLIDWORKS IS PROHIBITED.

SOLIDWORKS Student Edition.
 For Academic Use Only.

		DIMENSIONS ARE IN INCHES TOLERANCES: FRACTIONAL ± ANGULAR: MACH ± BEND ± TWO PLACE DECIMAL ± THREE PLACE DECIMAL ±	NAME	DATE	
			DRAWN		
			CHECKED		
			ENG APPR.		
			MFG APPR.		
			Q.A.		
			COMMENTS:		
		MATERIAL			
		FINISH			
		APPLICATION			
		DO NOT SCALE DRAWING			
			SIZE	DWG. NO.	REV.
			A	flange for safety relief	
			SCALE:1:4	WEIGHT:	SHEET 1 OF 1

2

1

SECTION III

Vacuum Can

2

1

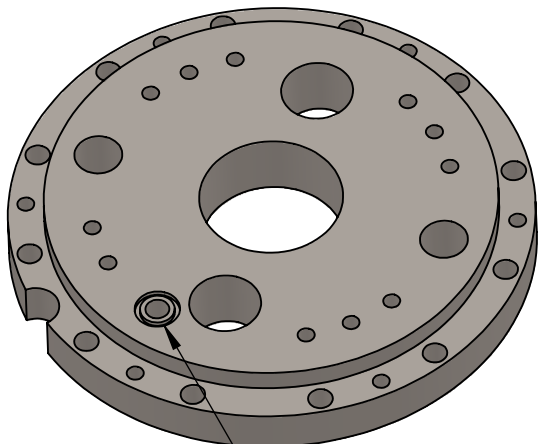

Weld groove .028 depth

B

B

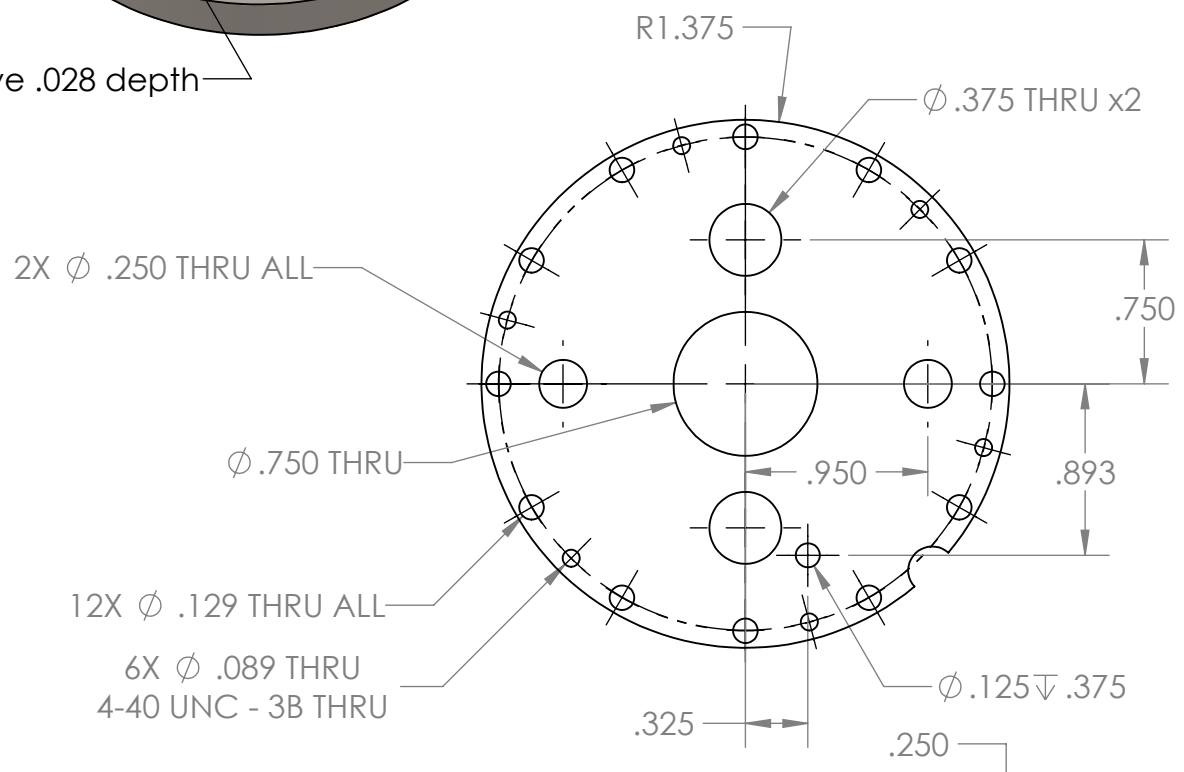

A

A

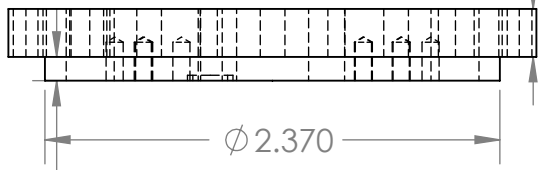

		DIMENSIONS ARE IN INCHES TOLERANCES: FRACTIONAL \pm ANGULAR: MACH \pm BEND \pm TWO PLACE DECIMAL \pm THREE PLACE DECIMAL \pm
		MATERIAL
		FINISH
		DO NOT SCALE DRAWING

	NAME	DATE
DRAWN		
CHECKED	125	
ENG APPR.		
MFG APPR.		
Q.A.		
COMMENTS:		

SIZE	DWG. NO.	REV.
A	vacuum can flange	
SCALE:1:2	WEIGHT:	SHEET 1 OF 2

PROPRIETARY AND CONFIDENTIAL
 THE INFORMATION CONTAINED IN THIS DRAWING IS THE SOLE PROPERTY OF SOLIDWORKS. NO REPRODUCTION IN PART OR AS A WHOLE WITHOUT THE WRITTEN PERMISSION OF SOLIDWORKS IS PROHIBITED.

SOLIDWORKS Student Edition.
For Academic Use Only.

2

1

2

1

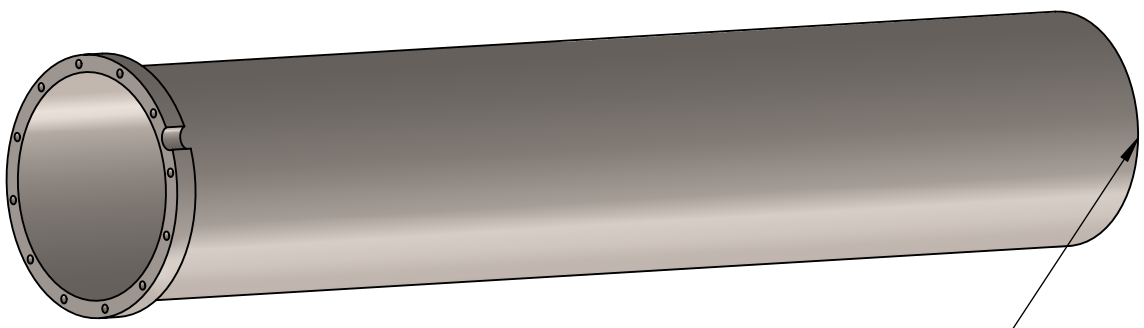

B

B

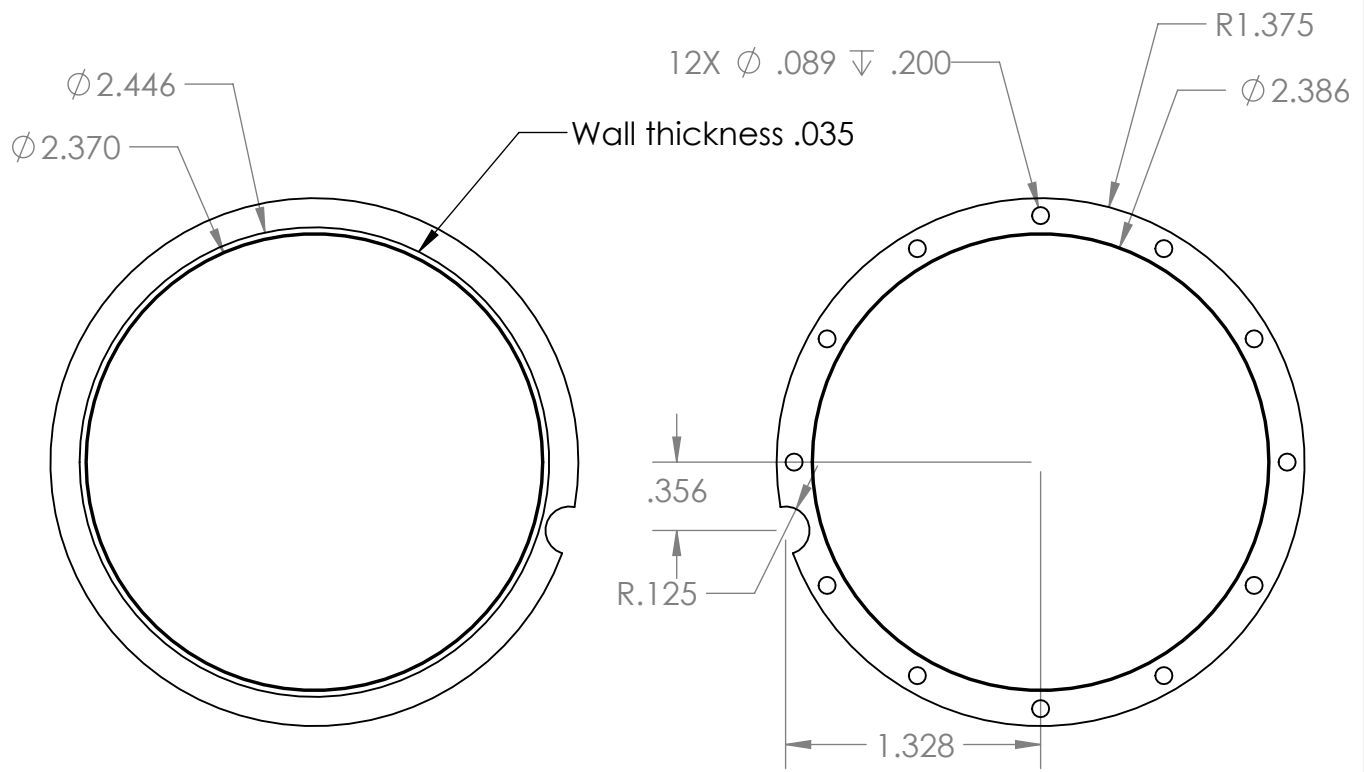
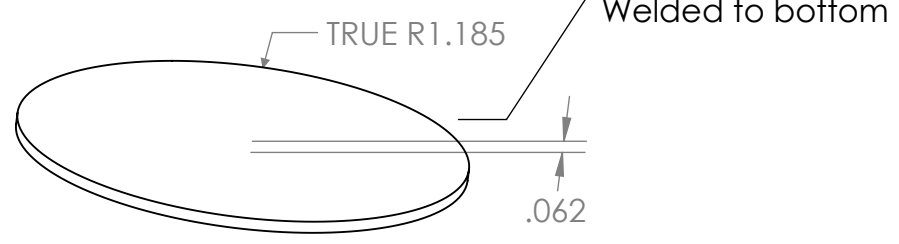

A

A

1:1

PROPRIETARY AND CONFIDENTIAL
 THE INFORMATION CONTAINED IN THIS DRAWING IS THE SOLE PROPERTY OF SOLIDWORKS. ANY REPRODUCTION IN PART OR AS A WHOLE WITHOUT THE WRITTEN PERMISSION OF SOLIDWORKS IS PROHIBITED.

SOLIDWORKS Educational Edition.
For Instructional Use Only.

		DIMENSIONS ARE IN INCHES TOLERANCES: FRACTIONAL ± ANGULAR: MACH ± BEND ± TWO PLACE DECIMAL ± THREE PLACE DECIMAL ±			
		MATERIAL			
		FINISH			
		DO NOT SCALE DRAWING			
		APPLICATION			
		USED ON			
		NEXT ASSY			

	NAME	DATE
DRAWN		
CHECKED		
ENG APPR.		
MFG APPR.		
Q.A.		
COMMENTS:		

SIZE	DWG. NO.	REV.
SCALE:1:4	WEIGHT:	SHEET 1 OF 1

2

1

2

1

B

B

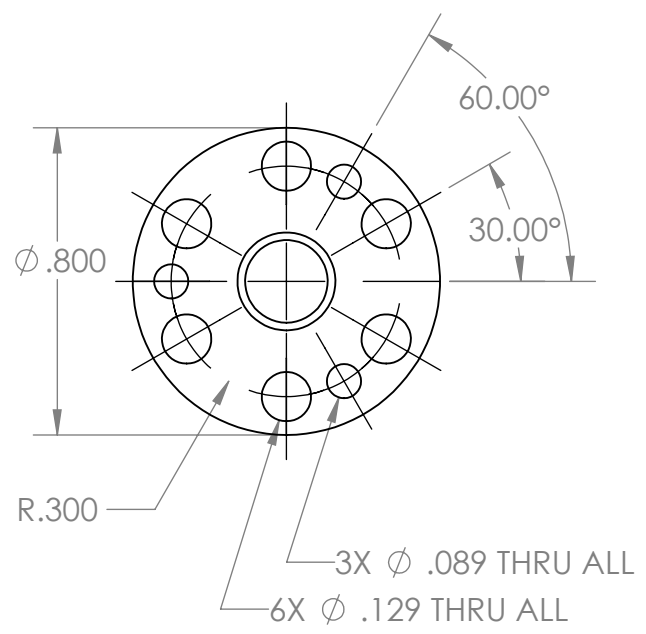
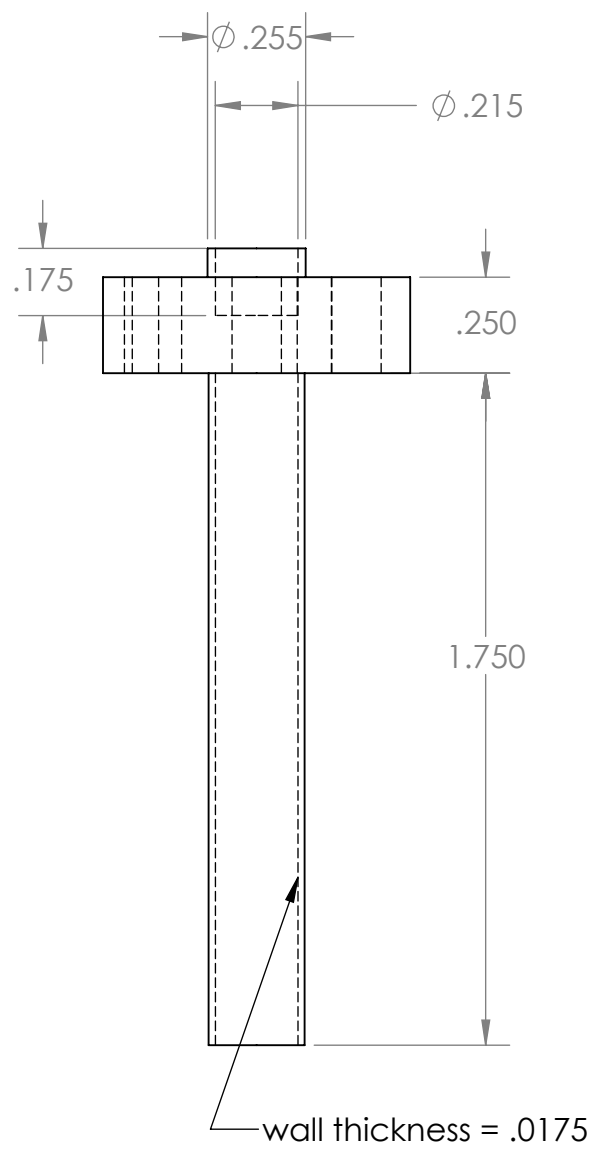
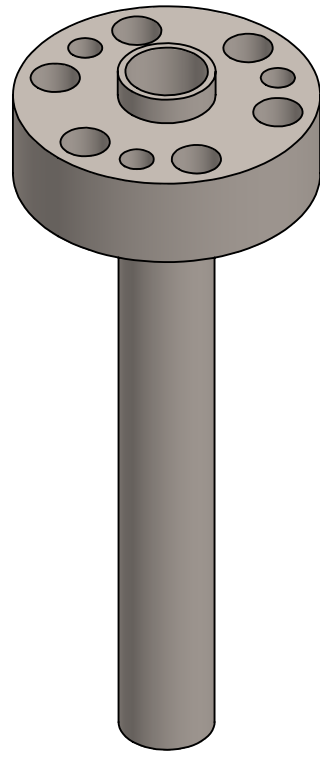

A

A

PROPRIETARY AND CONFIDENTIAL
 THE INFORMATION CONTAINED IN THIS DRAWING IS THE SOLE PROPERTY OF SOLIDWORKS. ANY REPRODUCTION IN PART OR AS A WHOLE WITHOUT THE WRITTEN PERMISSION OF SOLIDWORKS IS PROHIBITED.

SOLIDWORKS Student Edition.
For Academic Use Only.

		DIMENSIONS ARE IN INCHES TOLERANCES: FRACTIONAL ± ANGULAR: MACH ± BEND ± TWO PLACE DECIMAL ± THREE PLACE DECIMAL ±	NAME	DATE
		MATERIAL	DRAWN	
		FINISH	CHECKED	
		NEXT ASSY USED ON	ENG APPR.	
		APPLICATION	MFG APPR.	
		DO NOT SCALE DRAWING	Q.A.	
			COMMENTS:	

SIZE	DWG. NO.	REV.
SCALE:2:1	WEIGHT:	SHEET 1 OF 1

A vacuum can extension

2

1

SECTION IV

Capillary

2

1

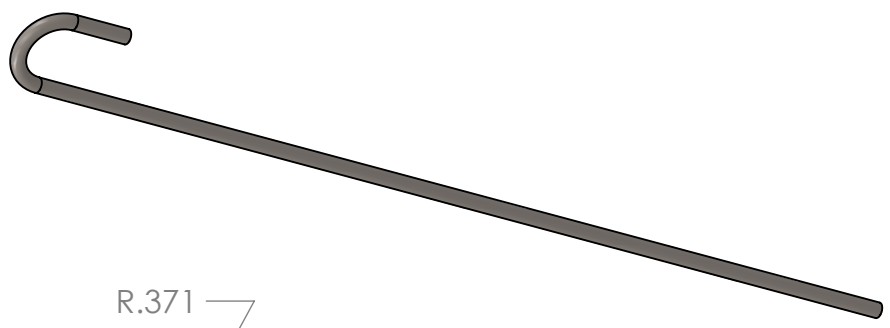

B

B

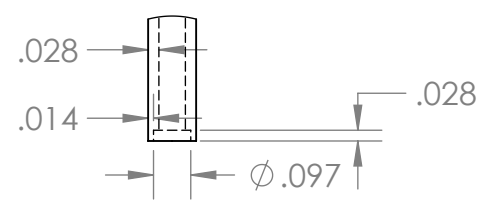
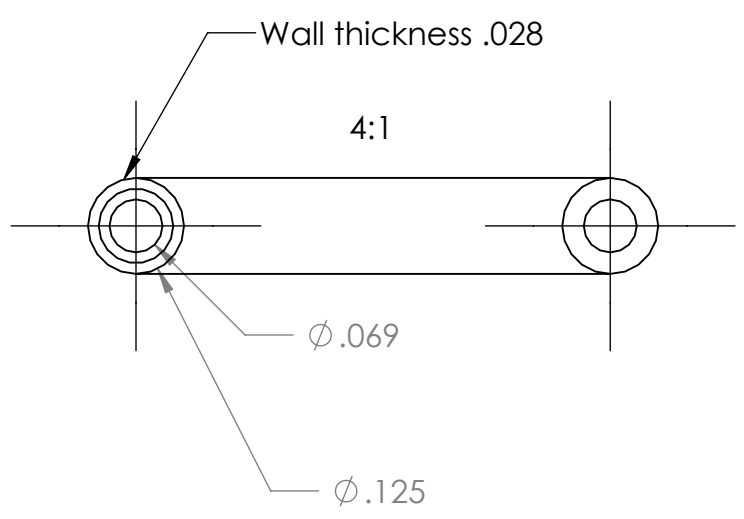
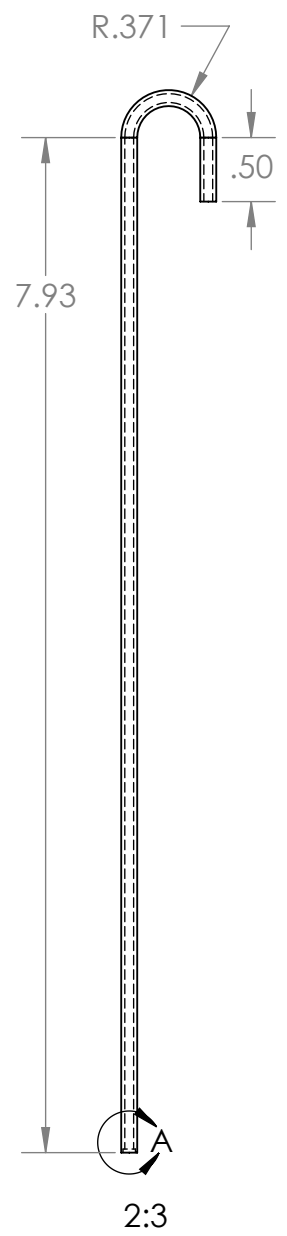

DETAIL A
SCALE 2 : 1

A

A

2:3

<p>PROPRIETARY AND CONFIDENTIAL</p> <p>THE INFORMATION CONTAINED IN THIS DRAWING IS THE SOLE PROPERTY OF SOLIDWORKS. ANY REPRODUCTION IN PART OR AS A WHOLE WITHOUT THE WRITTEN PERMISSION OF SOLIDWORKS IS PROHIBITED.</p>		DIMENSIONS ARE IN INCHES TOLERANCES: FRACTIONAL ± ANGULAR: MACH ± BEND ± TWO PLACE DECIMAL ± THREE PLACE DECIMAL ±	NAME	DATE	<p>SIZE DWG. NO. REV.</p> <p>A capillary shield</p> <p>SCALE:1:2 WEIGHT: SHEET 1 OF 1</p>
			DRAWN		
			CHECKED		
			ENG APPR.		
			MFG APPR.		
		MATERIAL SS	COMMENTS:		
		FINISH			
		APPLICATION			
		DO NOT SCALE DRAWING			

SOLIDWORKS Student Edition.
For Academic Use Only.

2

1

2

1

B

B

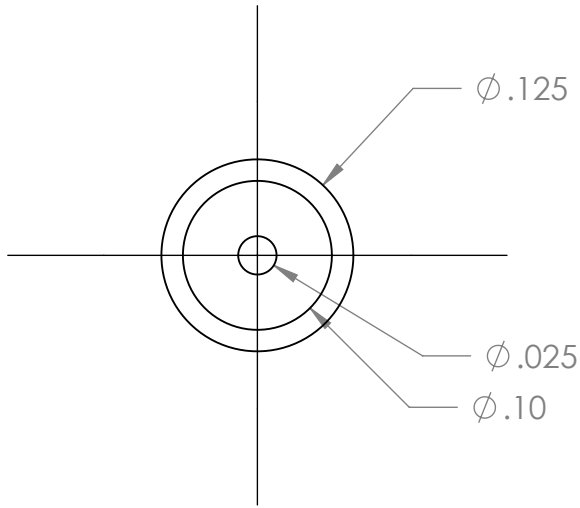
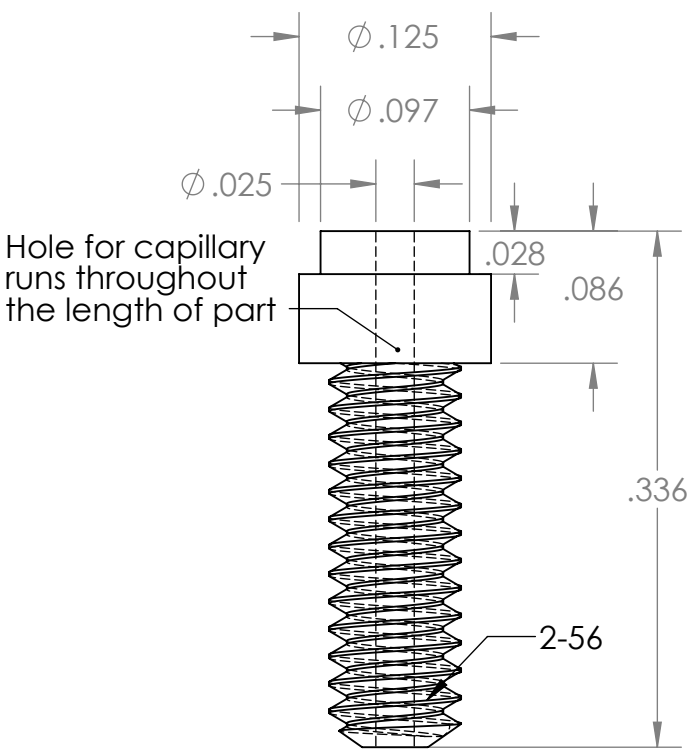
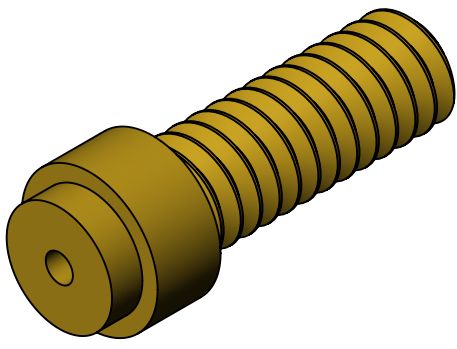

8:1

A

A

PROPRIETARY AND CONFIDENTIAL
 THE INFORMATION CONTAINED IN THIS DRAWING IS THE SOLE PROPERTY OF SOLIDWORKS. ANY REPRODUCTION IN PART OR AS A WHOLE WITHOUT THE WRITTEN PERMISSION OF SOLIDWORKS IS PROHIBITED.

SOLIDWORKS Student Edition.
For Academic Use Only.

		DIMENSIONS ARE IN INCHES TOLERANCES: FRACTIONAL \pm ANGULAR: MACH \pm BEND \pm TWO PLACE DECIMAL \pm THREE PLACE DECIMAL \pm			
		MATERIAL: Brass			
		FINISH:			
		DO NOT SCALE DRAWING			

	NAME	DATE
DRAWN		
CHECKED		
ENG APPR.		
MFG APPR.		
Q.A.		
COMMENTS:		

SIZE	DWG. NO.	REV.
SCALE: 8:1	WEIGHT:	SHEET 1 OF 1

capillary bath side brass ext thread

2

1

2

1

B

B

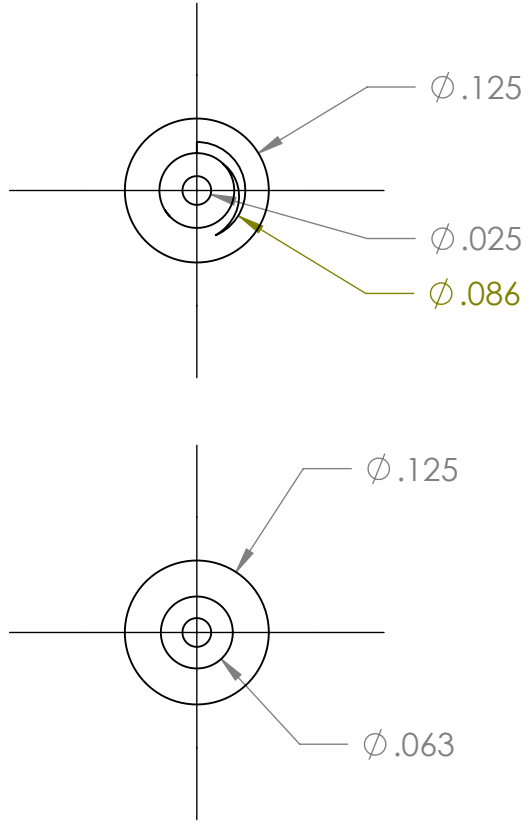
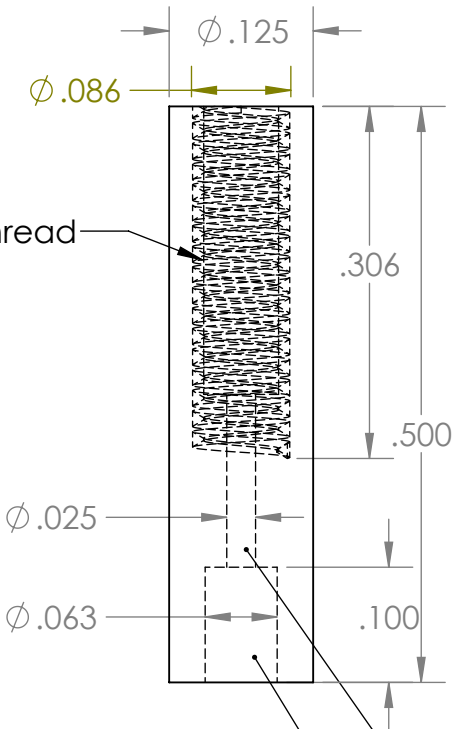
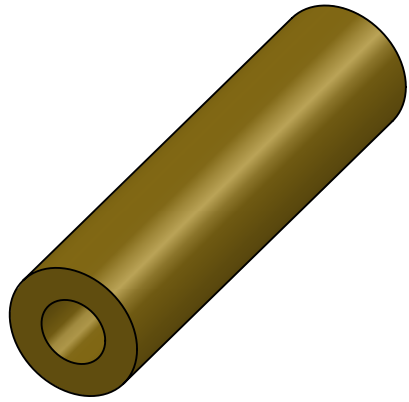

2-56 internal thread

capillary fits in this hole
filter sits here

A

A

6:1

PROPRIETARY AND CONFIDENTIAL
 THE INFORMATION CONTAINED IN THIS DRAWING IS THE SOLE PROPERTY OF SOLIDWORKS. ANY REPRODUCTION IN PART OR AS A WHOLE WITHOUT THE WRITTEN PERMISSION OF SOLIDWORKS IS PROHIBITED.

SOLIDWORKS Student Edition.
For Academic Use Only.

		DIMENSIONS ARE IN INCHES TOLERANCES: FRACTIONAL \pm ANGULAR: MACH \pm BEND \pm TWO PLACE DECIMAL \pm THREE PLACE DECIMAL \pm		NAME	DATE
		MATERIAL Brass			
		FINISH			
		DO NOT SCALE DRAWING			

DRAWN		
CHECKED		
ENG APPR.		
MFG APPR.		
Q.A.		
COMMENTS:		

SIZE	DWG. NO.	REV.
SCALE:4:1	WEIGHT:	SHEET 1 OF 1

2

1

SECTION V

Pot

2

1

B

B

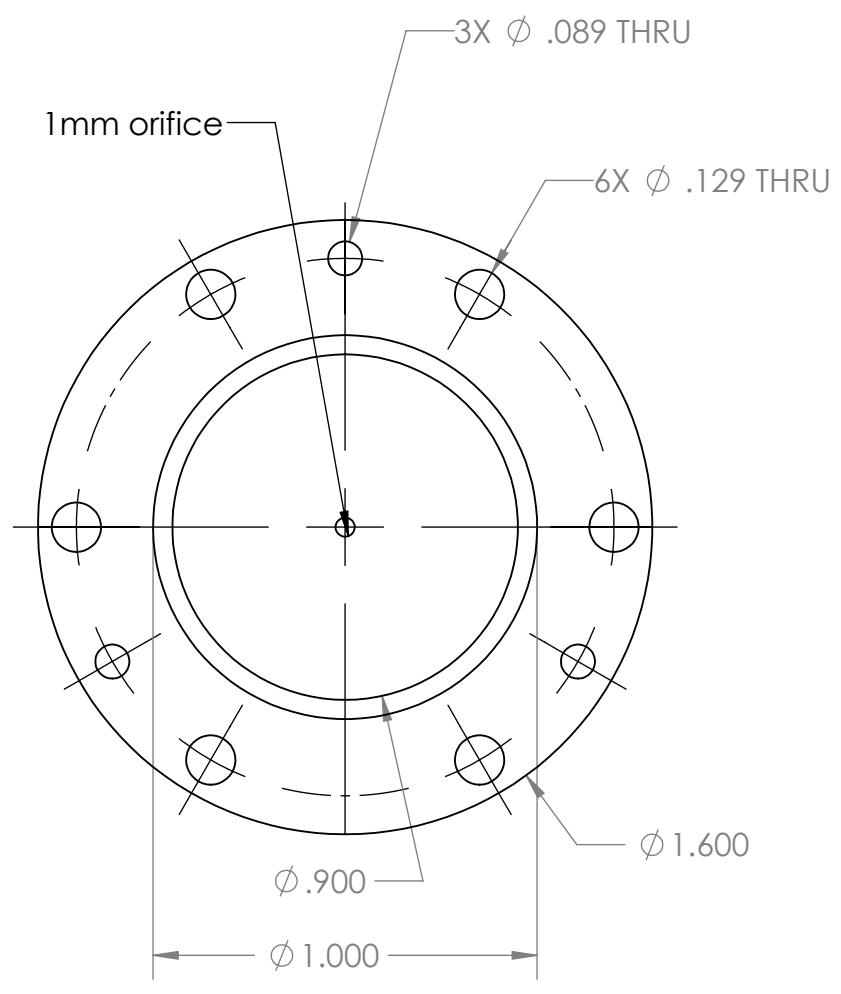
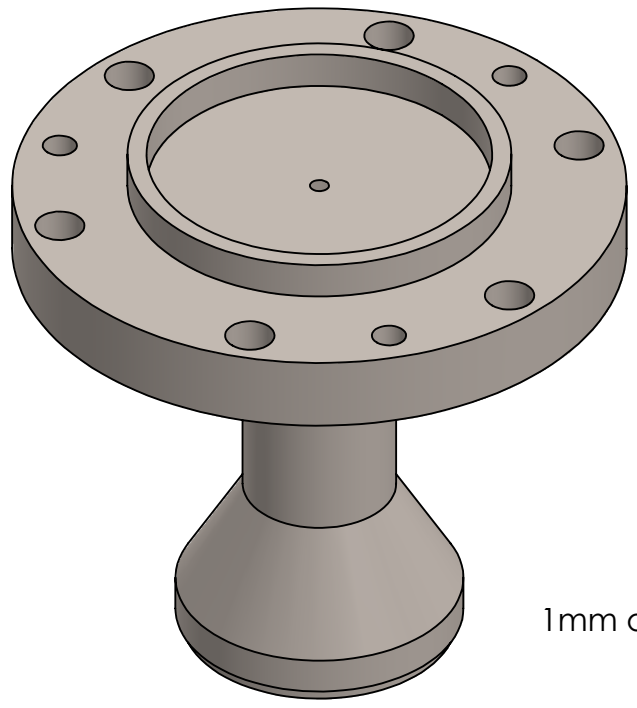

A

A

PROPRIETARY AND CONFIDENTIAL
 THE INFORMATION CONTAINED IN THIS DRAWING IS THE SOLE PROPERTY OF <COMPANY NAME>. ANY REPRODUCTION IN PART OR AS A WHOLE WITHOUT THE WRITTEN PERMISSION OF <COMPANY NAME> IS PROHIBITED.

		DIMENSIONS ARE IN INCHES		NAME	DATE
		TOLERANCES:		DRAWN	
		FRACTIONAL ±		CHECKED	
		ANGULAR: MACH ± BEND ±		ENG APPR.	
		TWO PLACE DECIMAL ±		MFG APPR.	
		THREE PLACE DECIMAL ±		Q.A.	
NEXT ASSY	USED ON	MATERIAL		COMMENTS:	
		FINISH			
APPLICATION		DO NOT SCALE DRAWING		SIZE	DWG. NO.
				SCALE:2:1	WEIGHT:
				REV.	
				SHEET 1 OF 2	

pot line adapter and lid (alp94@cornell.edu)

2

1

2

1

B

B

A

A

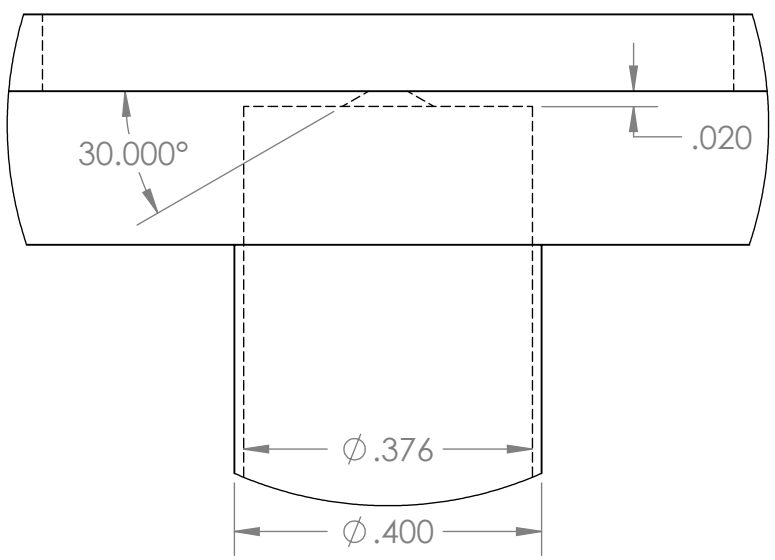
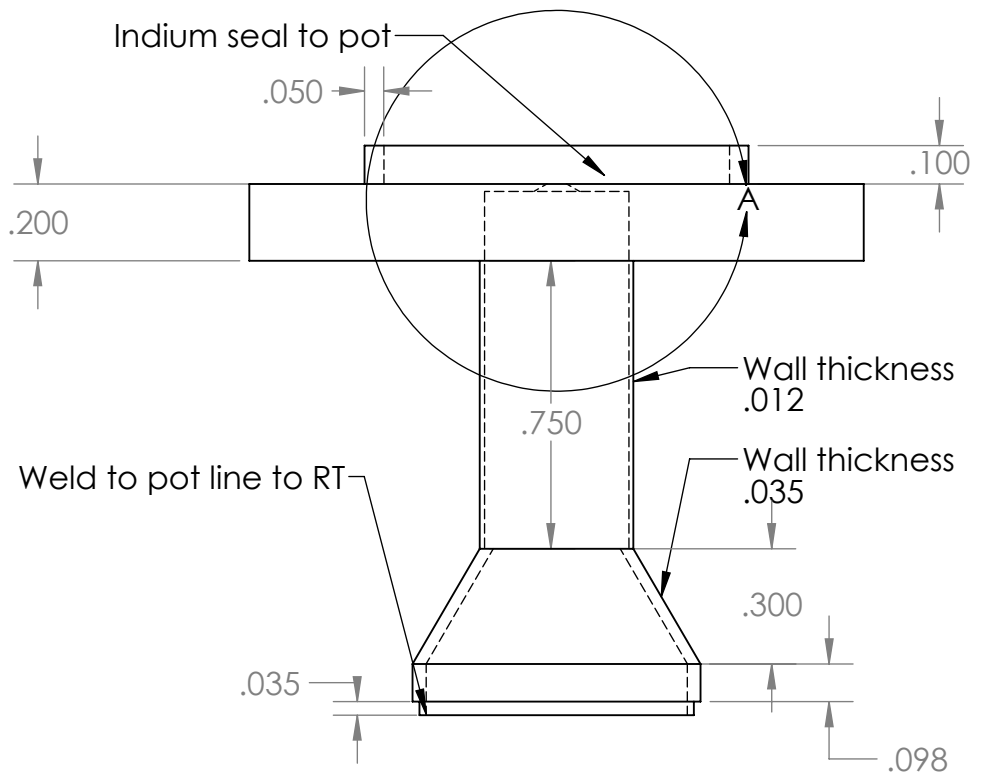

DETAIL A
SCALE 4 : 1

PROPRIETARY AND CONFIDENTIAL
 THE INFORMATION CONTAINED IN THIS DRAWING IS THE SOLE PROPERTY OF <COMPANY NAME>. ANY REPRODUCTION IN PART OR AS A WHOLE WITHOUT THE WRITTEN PERMISSION OF <COMPANY NAME> IS PROHIBITED.

		DIMENSIONS ARE IN INCHES		NAME	DATE
		TOLERANCES:		DRAWN	
		FRACTIONAL ±		CHECKED	
		ANGULAR: MACH ± BEND ±		ENG APPR.	
		TWO PLACE DECIMAL ±		MFG APPR.	
		THREE PLACE DECIMAL ±		Q.A.	
		MATERIAL		COMMENTS:	
NEXT ASSY	USED ON	FINISH			
APPLICATION		DO NOT SCALE DRAWING			
				SIZE	DWG. NO.
				SCALE:2:1	WEIGHT:
				REV.	
				SHEET 2 OF 2	

pot line adapter and lid (alp94@cornell.edu)

2

1

2

1

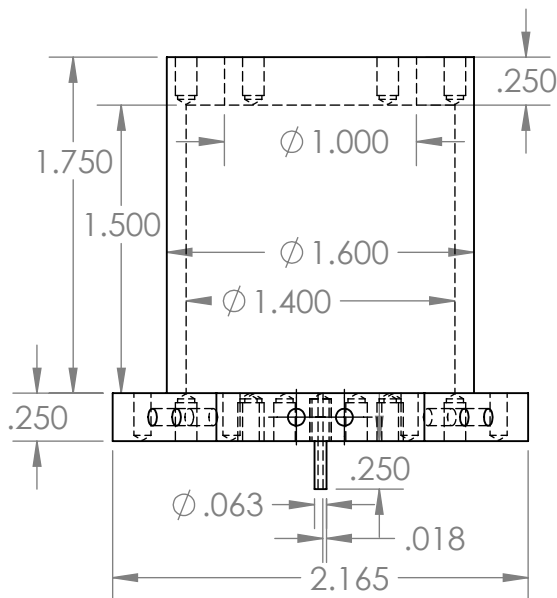
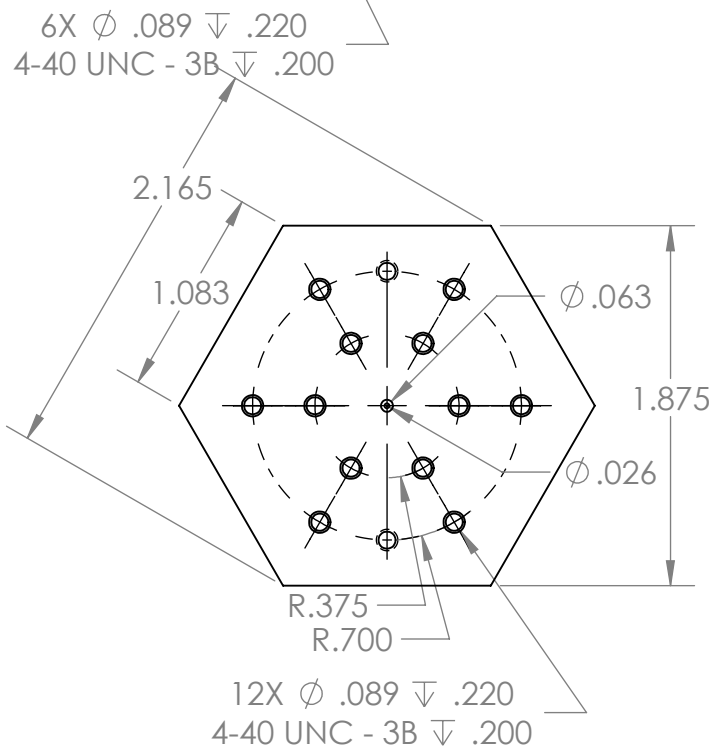
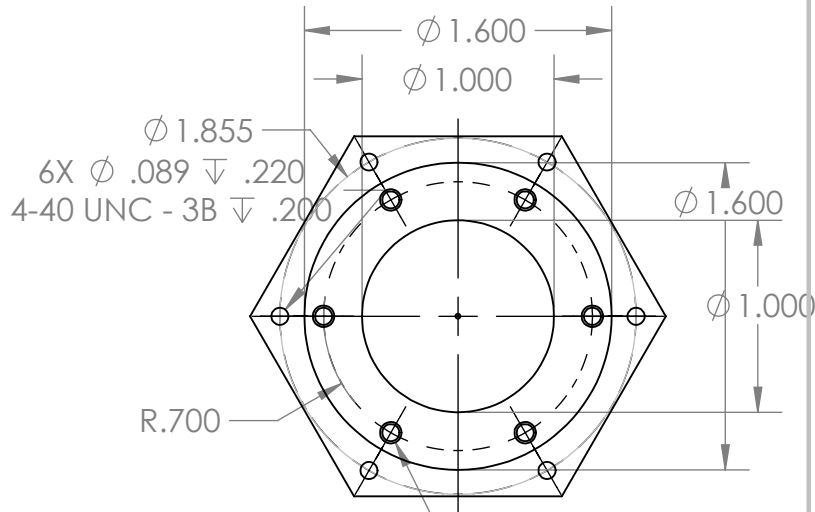
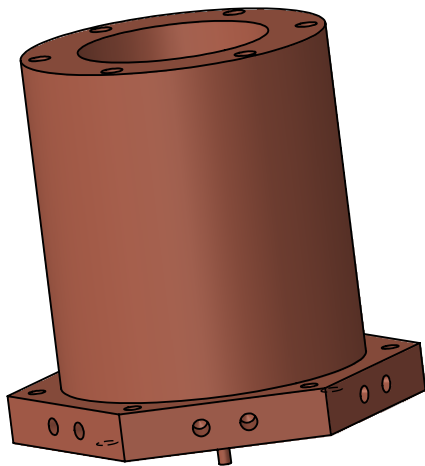

B

B

A

A

PROPRIETARY AND CONFIDENTIAL

THE INFORMATION CONTAINED IN THIS DRAWING IS THE SOLE PROPERTY OF SOLIDWORKS. ANY REPRODUCTION IN PART OR AS A WHOLE WITHOUT THE WRITTEN PERMISSION OF SOLIDWORKS IS PROHIBITED.

SOLIDWORKS Student Edition.
For Academic Use Only.

		DIMENSIONS ARE IN INCHES TOLERANCES: FRACTIONAL ± ANGULAR: MACH ± BEND ± TWO PLACE DECIMAL ± THREE PLACE DECIMAL ±	NAME	DATE
			DRAWN	
			CHECKED	
			ENG APPR.	
			MFG APPR.	
			Q.A.	
			COMMENTS:	
		MATERIAL		
		FINISH		
		APPLICATION		
		DO NOT SCALE DRAWING		

SIZE	DWG. NO.	REV.
A	pot monolithic	
SCALE:1:1	WEIGHT:	SHEET 1 OF 1

2

1